

OPERATORS AND PARTS MANUAL NO. 07-1-8720/8865

MEYER

INDUSTRIAL SERIES
TWIN EXPELLER SUPER SPREADER

MODEL 8720

MODEL 8865

PATENTED
U.S. PATENT NUMBER

5,368,236

5,501,404



8865 SPREADER



8720 SPREADER

DO NOT OPERATE EQUIPMENT UNTIL THIS MANUAL HAS BEEN READ AND UNDERSTOOD

MEMBER



MANUFACTURED BY
Meyer Mfg. Corp.



Over
60 years
of service
to our customers

County Hwy. A West
P.O. Box 405
Dorchester, Wisconsin 54425-0405
Phone 715-654-5132 • FAX 715-654-5513
1-800-325-9103
www.meyermfg.com
E-mail: sales@meyermfg.com

TABLE OF CONTENTS

INTRODUCTION	4
SAFETY PRECAUTIONS	5
SAFETY FIRST	6
PRE-OPERATION	8
TRANSPORTING	9
OPTIONAL TRUCK MOUNT SPREADERS	10
USE OF SAFETY CHAIN	10
FREEZING WEATHER OPERATION	11
OPERATION	12
LOADING	12
UNLOADING	12
SHEAR SPROCKET INSTRUCTIONS	13
STORAGE AFTER USE	14
PTO DRIVELINE	15
DRIVELINE ATTACHMENT	15
PTO SETUP	15
LUBRICATION	16
LUBRICATION	16
PRIOR TO USE	16
ADJUSTMENTS	17
FRONT DRIVE ROLLER CHAINS	17
SPINNER MATERIAL GUIDES	19
SHEAR ARM MATERIAL GUIDE ADJUSTMENT	19
LUBRICATION	20
REPAIR PARTS	22
918-0308 (STANDARD 8720) (OPTIONAL 8865) (SERIAL #SI078720288-SI088720425) (FOR EARLIER MODELS SEE PAGE 24.)	22
918-0408 (STANDARD 8720) (OPTIONAL 8865) (SERIAL #SI088720426 & LATER)	22
PTO DRIVE SHAFT-STAR PROFILE	22
1000 RPM 1-3/8 21 SPLINE WWE2480 (80 DEGREE C.V.)	22
PTO DRIVE SHAFT ASSEMBLY	24
FIRST REDUCTION & SPINNER DRIVE	30
SECOND REDUCTION DRIVE	32
THIRD REDUCTION DRIVE	34
FINAL REDUCTION, RH AUGER DRIVE	36
FINAL REDUCTION, LH AUGER & THIRD AUGER DRIVE	38
BODY, SHIELDS & AUGERS - 8720 SPREADER	40
BODY, SHIELDS & AUGERS - 8865 SPREADER	42
REAR GATE & SHIELDS	44
SPINNERS & GEARBOXES	46
SPINNER GEAR REDUCER - LEFT HAND (1:1) #19-0129	48
SPINNER GEAR REDUCER - CENTER (1:1) #19-0130	49
CORNER GEAR REDUCER - RIGHT HAND	50
AXLE & WHEELS (STANDARD 8720)	51
AXLE & WHEELS, HI-FLOAT PACKAGE	52
(STANDARD 8865) (OPTIONAL 8720)	52
LIGHTS	53
INSTRUCTIONS FOR AUTOMATIC CHAIN OILER	55
OIL-KIT	56
“TROUBLE SHOOTING”	58
“MAINTENANCE RECORD”	59
MEYER EQUIPMENT WHEEL TORQUE	60
TIRE INFLATION	60
8720/8865 SPREADER W/ BRAKES TIRE WHEEL TORQUE	60
DIMENSIONS & SPECIFICATIONS	61
DIMENSIONS & SPECIFICATIONS	62

NEW MEYER INDUSTRIAL SPREADER

MANUFACTURER'S WARRANTY

- I. The "Product Registration & Inspection Certificate" along with the original billing invoice "Owners Registration Form" must be completed in full and promptly returned to Meyer Mfg. Corp. for this warranty to become both valid and effective. All warranties on New Meyer Super Spreaders shall apply only to the original retail customer from an authorized Meyer Mfg. Corp. dealership.
- II. This warranty shall not apply to any Meyer Super Spreader which has been subjected to misuse, negligence, alteration, accident, incorrect operating procedures, or which shall have been repaired with parts other than those obtained through Meyer Mfg. Corp.
- III. Meyer Mfg. Corp. warrants New Meyer Super Spreaders to be free from defects in material and workmanship under recommended use and maintenance service, as stated in the Operator's and Parts Manual," as follows:
 - A. Meyer Mfg. Corp. will repair or replace F.O.B. Dorchester, WI, as Meyer Mfg. Corp. elects, any part of a new Meyer Super Spreader which is defective in material or workmanship:
 1. Without charge for either parts or labor during the first (1) year from purchase date to the original retail customer.
 - B. In addition to the above basic warranty, Meyer Mfg. Corp. will repair or replace F.O. B. Dorchester, WI as Meyer Mfg. Corp. elects:

Ten (10) Years: After a period of (1) year, the spreader tank body is warranted against rust-through for an additional period of (9) years. (Pro-Rated Parts Only). Parts included, front and rear end panels, side panels, and auger trough.
- IV. COMMERCIAL USE: Coverage as in paragraph III A1 ONLY, except warranty coverage is for (90) days for parts and labor to the original commercial retail customer.
- V. Repairs eligible for labor warranty must be made by Meyer Mfg. Corp. or an authorized Meyer dealership. The original retail customer is responsible for the transportation of the super spreader to the dealership for warranty service or for any service call expenses.
- VI. Except as stated above, Meyer Mfg. Corp. shall not be liable for injuries or damages of any kind or nature, direct, consequential, or contingent, to persons or property. This warranty does not extend to loss of crop or for any other reasons.
- VII. No person is authorized to give any other warranties or to assume any other obligation on Meyer Mfg. Corp.'s behalf unless made or assumed in writing by Meyer Mfg. Corp. This warranty is the sole and exclusive warranty which is applicable in connection with the manufacture and sale of this product and Meyer Mfg. Corp.'s responsibility is limited accordingly.
- VIII. This warranty is effective on all sales of Meyer Super Spreaders made after January 1, 1992.

INTRODUCTION

Congratulations on your purchase of a new Meyer farm equipment product. Undoubtedly you have given much consideration to your purchase and we're proud that you have selected Meyer. Pride in craftsmanship, engineering and customer service have made Meyer products the finest in the farm equipment industry today.

There is no substitute for quality. That is why thousands of people like you have purchased Meyer farm equipment. They felt it was the best equipment to serve their farming needs, now and in years to come. We ask that you follow our policy of "safety first," and we strongly suggest that you read through the owner's manual before operating your Meyer farm equipment.

Meyer Manufacturing Corporation wants to thank you for not compromising quality. We are determined to offer excellence in customer service as well as provide you with the very best value for your dollar.

REMEMBER:

**FARM EQUIPMENT BUYERS
TRUST THE NAME MEYER!**

Sincerely,

All Employees of
MEYER MANUFACTURING CORPORATION

Meyer Mfg. Corp. reserves the right to make improvements in design, or changes in specifications at any time, without incurring any obligation to owners of units previously sold.

This supersedes all previous published instructions.

IMPORTANT:

At the front of this manual is a Product Registration and Inspection Certificate. Be sure your dealer has completed this certificate and promptly forwarded a copy to Meyer Mfg. to validate the manufacturer's warranty. The product model and serial number are recorded on this certificate and below for proper identification of your Meyer Industrial Spreader by your dealer and the manufacturer when ordering repair parts. The serial number plate is found on the upper left front corner of the spreader tank or stamped in the left front frame channel.

Model No. _____

Serial No. _____

Date of Purchase _____

At the back of this manual is the repair parts section. All replacement parts are to be obtained from or ordered through your Meyer dealership. When ordering repair parts, refer to the parts section and give complete information including quantity, correct part number, detailed description and even Model No. and Serial No. of the Meyer Industrial Spreader which needs repair parts.

NOTE: All references to right hand (RH), left hand (LH), front and rear apply to the product as viewed from the rear of the spreader.

SAFETY PRECAUTIONS



This symbol is used to call attention to instructions concerning personal safety. Be sure to observe and follow these instructions. Take time to be careful!



WARNING: BEFORE ATTEMPTING TO OPERATE THIS SPREADER, READ AND STUDY THE FOLLOWING SAFETY INFORMATION. IN ADDITION, MAKE SURE THAT EVERY INDIVIDUAL WHO OPERATES OR WORKS WITH THE SPREADER, WHETHER FAMILY MEMBER OR EMPLOYEE, IS FAMILIAR WITH THESE SAFETY PRECAUTIONS.

Require anyone who will operate this spreader to read and completely understand this Owner's Manual. Give necessary instructions!

DO NOT operate, service, inspect or otherwise handle this spreader until all operators have read this Owner's Manual and have been properly trained in the intended usage of the spreader.

Do not allow minors (children) or inexperienced persons to operate this spreader.

If the spreader becomes clogged, shut off the tractor engine and allow all mechanisms to stop. Disconnect PTO shaft and hydraulic hoses (relieve hydraulic pressure). Then, clean or work on the spreader as required.

Always shut off power and disconnect PTO drive shaft and unhook hydraulic hoses (relieve hydraulic pressure) from tractor to prevent accidental startup or unexpected movement before working on machine.

Do not clean, adjust, or lubricate while spreader is in motion.

Make sure all hydraulic fittings are tight and that all hoses are in good condition. Hydraulic fluid escaping under pressure can have sufficient force to penetrate skin and cause serious injury. Never investigate for hydraulic leaks by using a part of the body to feel for escaping fluid.

Inspect when first delivered and regularly thereafter; that all connections and bolts are tight and secure before operating.

Know how to stop the spreader before starting it!

Do not operate until all shields, covers, and guards are in place.

Make certain everyone is clear of the spreader before applying power.

Keep hands, feet and clothing away from moving parts. Loose or floppy clothing should not be worn by the operator.

Stay well clear of the spreader's rear discharge spinners while operating.

Do not step up on any part of the spreader at any time. Do not use PTO guard as a step.

Do not step over the power take-off shaft. Stay clear of the PTO at all times.

Keep PTO shaft telescoping tube shields turning freely. Keep PTO master shield on tractor. Replace shields missing or damaged.

Never operate PTO above normal 1000 RPM rating. Tractors PTO MUST match implement PTO.

Use only properly rated tires.

Do not tow at speeds in excess of 20 MPH when transporting this spreader. Never exceed a safe travel speed.

Observe all applicable traffic laws when transporting on public roadways (where legal to do so). Check local laws for all highway lighting and marking requirements.

Always install a SMV emblem on this spreader for transporting on roadways and keep the emblem clean and bright.

When towing the spreader on public roads a safety chain of sufficient strength to support, along the line of travel, the gross weight of the spreader must be used (See Maximum Load Weight Chart in the Transporting Section). The safety chain should be attached per diagram in the Transporting Section.

MEYER MFG. CORP. PROVIDES GUARDS FOR EXPOSED MOVING PARTS FOR THE OPERATOR'S PROTECTION; HOWEVER, SOME AREAS CANNOT BE GUARDED OR SHIELDED IN ORDER TO ASSURE PROPER OPERATION. THE OPERATOR'S MANUAL AND DECALS ON THE MACHINE ITSELF WARN YOU OF DANGERS AND MUST BE READ AND OBSERVED CLOSELY.

**STUDY THE ABOVE SAFETY RULES
FAILURE TO HEED MAY RESULT IN SERIOUS PERSONAL INJURY OR DEATH.**

SAFETY FIRST



A brief definition of signal words that may be used in this manual is as follows:

situation which, if not avoided, COULD result in death or serious injury, and includes hazards that are exposed when guards are removed.

 **DANGER** indicates an imminently hazardous situation which, if not avoided, WILL result in serious injury or death.

 **CAUTION** indicates a potentially hazardous situation which, if not avoided, MAY result in minor or moderate injury. It is also used to alert against unsafe practices.

 **WARNING** indicates a potentially hazardous

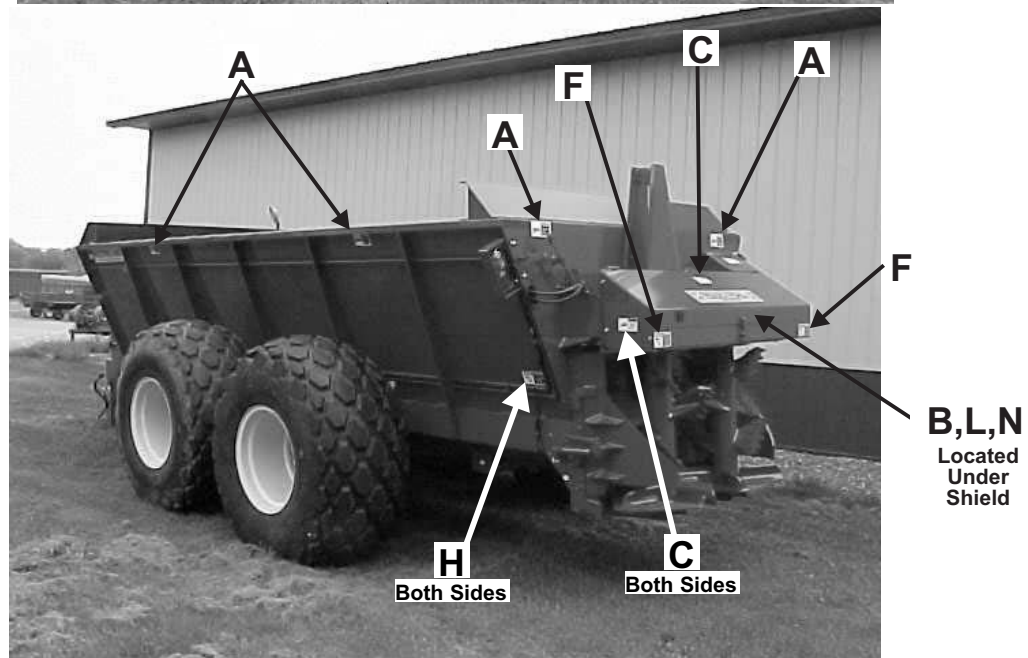
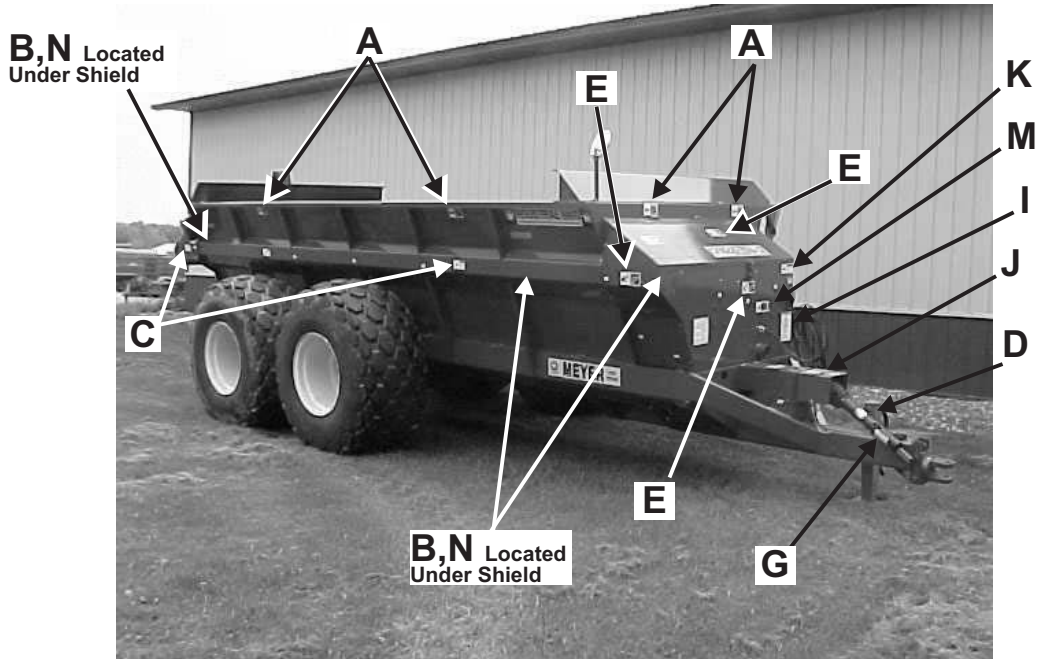

 **CAUTION:** READ ALL DECALS ON THE SPREADER AND IN THIS MANUAL. KEEP THESE DECALS CLEAN AND REPLACE ANY LOST OR DESTROYED DECALS. BECOME FAMILIAR WITH ALL TRACTOR AND SPREADER CONTROLS.

SAFETY FIRST

The Meyer Super Spreader is manufactured with operator safety in mind. Located on the manure spreader are various decals to aid in operation and warn of danger or caution areas. Pay close attention to all decals on the spreader.

DO NOT REMOVE ANY DECALS. IF DECALS ARE LOST, DAMAGED OR IF MANURE SPREADER IS REPAINTED, REPLACE DECALS. REMEMBER: DECALS ARE FOR YOUR PROTECTION AND INFORMATION.



DECAL A. PART NO. 46-0001-5



DECAL B. PART NO. 46-0001-26



DECAL C. PART NO. 46-3600-9



DECAL D. PART NO. 46-3600-6



DECAL G. PART NO. 46-0001-13



DECAL E. PART NO. 46-0001-4



DECAL F. PART NO. 46-3600-1



DECAL H. PART NO. 46-3600-8

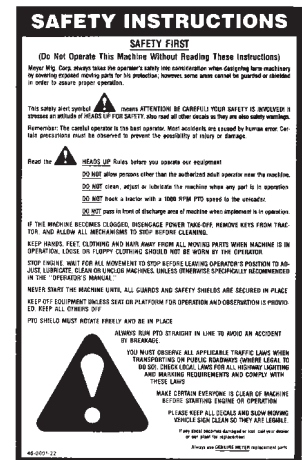

DECAL I. PART NO. 46-0001-22



DECAL J. PART NO. 46-0004-2

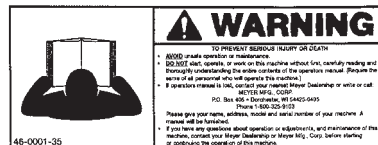

DECAL K. PART NO. 46-0001-35



DECAL L. PART NO. 46-5570-3



Decal M. Part No. 46-8500-7



Decal N. Part No. 46-3600-7

CAUTION: READ ALL DECALS ON THE SPREADER AND IN THIS MANUAL. KEEP THESE DECALS CLEAN AND REPLACE ANY LOST OR DESTROYED DECALS. BECOME FAMILIAR WITH ALL TRACTOR AND SPREADER CONTROLS.

PRE-OPERATION

WARNING: BEFORE OPERATING, READ THIS OWNERS MANUAL COMPLETELY. PAY PARTICULAR ATTENTION TO THE “SAFETY PRECAUTION” AND “SAFETY FIRST” PAGES. READ ALL SAFETY MESSAGES HIGHLIGHTED BY “SAFETY ALERT SYMBOLS” THROUGHOUT THE MANUAL.

This spreader must be operated with a 1000 RPM PTO. The hitch of the spreader is designed for a standard tractor drawbar. Adjust the drawbar at 15 to 22 inches above the ground. Extend or shorten the drawbar so horizontal distance from end of tractor PTO shaft to center of the hitch pin hole is 20" (1 3/4-20), 16" (1 3/8-21). Secure the drawbar so that the hitch pin hole is located directly below the PTO drive line. See figure 1 for location of standard measurements.

An improperly located hitch point may cause damage to the universal joints of the PTO drive shaft. Conforming to the standard 16" or 20" drawbar & PTO relationship will ensure that the PTO drive shaft will not become over-extended.

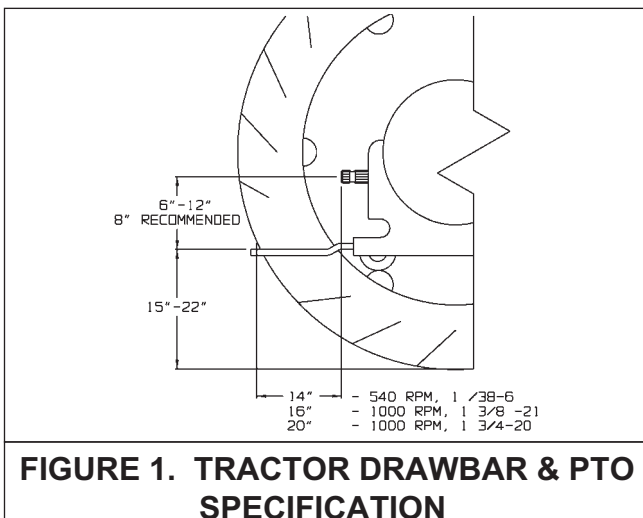

FIGURE 1. TRACTOR DRAWBAR & PTO SPECIFICATION

WITH INITIAL HOOK-UP TO YOUR NEW MEYER SPREADER TEST PTO TRAVEL BY TURNING EQUIPMENT IN BOTH DIRECTIONS OBSERVING THE MINIMUM AND MAXIMUM TRAVEL DIMENSIONS AS SHOWN PER DRAWING ON FIGURE 5, PAGE 15.

DANGER: DO NOT OPERATE WITHOUT PTO GUARD ON SPREADER AND ON TRACTOR. MAINTAIN PTO DRIVE SHAFT GUARD TUBES IN OPERATING CONDITION. REPLACE THEM IF DAMAGED AND NOT TURNING FREELY. FAILURE TO HEED MAY RESULT IN SERIOUS PERSONAL INJURY OR DEATH.

WARNING: INSPECT REGULARLY THAT ALL CONNECTIONS AND BOLTS ARE TIGHT AND SECURE BEFORE OPERATING. FAILURE TO HEED MAY RESULT IN SERIOUS PERSONAL INJURY OR DEATH.

Check for proper assembly and adjustment and make sure that all bolts are tightened. Securely retighten after a few hours of operation, as bolts can loosen up on new machinery. Check wheel lug nuts upon delivery and periodically thereafter. Lug nuts should be tightened at 250-265 ft./lbs. of torque. Check the tires and inflate to the recommended pressure. See chart on page 60. Inspect all adjustments on the spreader to be sure they are proper and to provide maximum performance. Lubricate the spreader completely if it is required and check the level of oil in the right rear corner gear box, and the gear grease in the expeller gear boxes.

WARNING: DO NOT OPERATE WITHOUT ALL SHIELDS, GUARDS AND COVERS INSTALLED. FAILURE TO HEED MAY RESULT IN SERIOUS PERSONAL INJURY OR DEATH.

Fasten the spreader hitch to the tractor drawbar with a hitch pin that cannot bounce out. Use a 1-5/16" to 1-3/8" diameter hitch pin to pull spreader.

Remove the weight from the jack (jack is not to be used when spreader is loaded). Remove the jack from round mount tube and move to the transport storage tube on the front of the spreader drive enclosure. Store in a horizontal position.

Before operation and after hitching the tractor to the spreader, connect the PTO drive shaft to the tractor. Slide spring loaded locking collar on PTO yoke rearward, and slide yoke onto the tractor PTO shaft. Release spring loaded collar. Be sure pins fall into groove of tractor PTO shaft and collar snaps forward into locking position.

CAUTION: DO NOT USE A STEEL HAMMER TO AID IN JOINING PTO PARTS.

Route hydraulic hoses through the hose support rod which is mounted to the hitch frame, figure 2. Connect the hydraulic hoses for the flow control rear gate to the tractor's double acting valve hydraulic system. Move the tractor hydraulic controls to observe proper flow gate

operation. If the controls operate the gate in opposite directions to what you expect, reverse the hydraulic hose connections at the tractor.

⚠ WARNING: HYDRAULIC FLUID ESCAPING UNDER PRESSURE CAN HAVE SUFFICIENT FORCE TO PENETRATE SKIN. KEEP ALL HOSES AND CONNECTIONS IN GOOD SERVICEABLE CONDITION. FAILURE TO HEED MAY RESULT IN SERIOUS PERSONAL INJURY OR DEATH.

Before loading spreader, slowly engage the tractor PTO and operate machine at idle speed for several minutes to insure the spreader is lubricated and operating properly.

TRANSPORTING

TRACTOR TOWING SIZE REQUIREMENTS

Use the following chart for calculating the minimum tractor weight.

MODEL	SPREADER EMPTY WEIGHT + LOAD = GW	MINIMUM TRACTOR WEIGHT UP TO 20 MPH
SV2636	6,100 + _____ = _____	2/3 of spreader gross weight
SV3245	7,640 + _____ = _____	2/3 of spreader gross weight
SV3954	8,650 + _____ = _____	2/3 of spreader gross weight
SI8720	11,445 + _____ = _____	2/3 of spreader gross weight
SI8865	18,140 + _____ = _____	2/3 of spreader gross weight

MATERIAL ESTIMATED WEIGHT PER CUBIC FOOT

MATERIAL	LBS / CU. FT.
LIME SLUDGE	110-115 LBS.
DRY FEEDLOT MANURE	63-65 LBS.
CHICKEN LITTER	63-65 LBS.
CAKE SLUDGE	62-65 LBS.
SEMI-SOLID MANURE	58-60 LBS.
PEN PACKED MANURE	30-35 LBS.
LIQUID MANURE	63-65 LBS.

SOURCE: ASAE

MAXIMUM SPREADER LOAD WEIGHTS					
Model	2636	3245T	3954T	8720T	8865T
Maximum Gross Weight (Pounds)	12,000	24,000	32,000	46,645	56,140
Total Net Weight (Pounds)	6,100	7,640	8,650	11,445	18,140
Cubic Foot Capacity**	181	227	272	468	562
Capacity in Gallons	1,355	1,694	2,033	3,500	4,200

**Struck capacity, heaped loads have significantly higher capacities

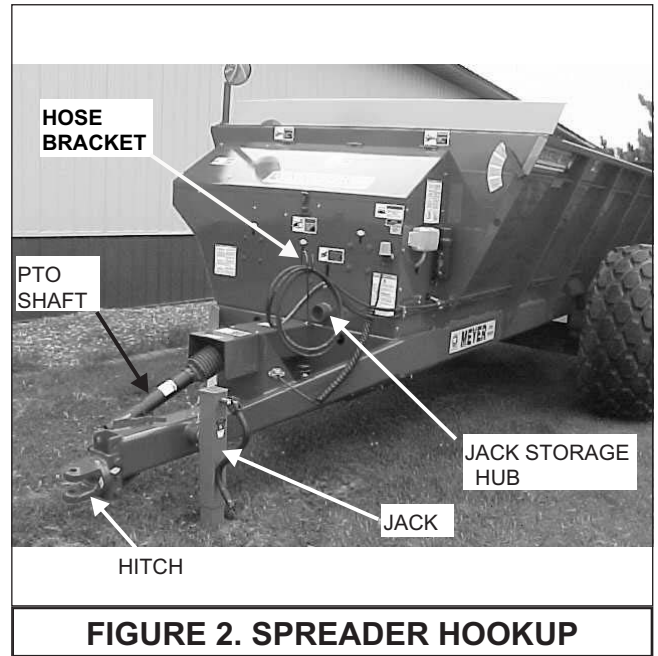

FIGURE 2. SPREADER HOOKUP

NOTE: HEAPED LOADS HAVE SIGNIFICANTLY HIGHER CAPACITIES

Check that the flow control rear gate is completely closed. It is unlawful to allow slurry to splash or leak onto public roads.

⚠ WARNING: DO NOT TOW AT SPEEDS GREATER THAN 20 MPH. FAILURE TO HEED MAY RESULT IN SERIOUS PERSONAL INJURY OR DEATH.

Operating speed is dictated by the terrain over which you are traveling. Always use caution. Avoid traveling on slopes or hills that are unsafe.

⚠ WARNING: OBSERVE ALL APPLICABLE TRAFFIC LAWS WHEN TRANSPORTING ON PUBLIC ROADWAYS. CHECK LOCAL LAWS FOR ALL HIGHWAY LIGHTING AND MARKING REQUIREMENTS.

⚠ WARNING: OBSERVE ALL APPLICABLE TRAFFIC LAWS WHEN TRANSPORTING ON PUBLIC ROADWAYS. CHECK LOCAL LAWS FOR ALL HIGHWAY LIGHTING AND MARKING REQUIREMENTS.

⚠ WARNING: INSTALL A SMV EMBLEM ON REAR OF SPREADER FOR TRANSPORTING ON ROADWAYS AND KEEP THIS EMBLEM CLEAN AND BRIGHT. FAILURE TO HEED MAY RESULT IN SERIOUS PERSONAL INJURY OR DEATH.

If you will travel on public roads and it is legal to do so, you must know all rules governing such operation. This will include lighting and brake requirements in addition to traffic rules. You may also be required to install a safety chain device on the spreader.

Check for traffic constantly. Be sure you can see that no one is attempting to pass you and that all traffic is sufficiently clear from you before making any turns.

OPTIONAL TRUCK MOUNT SPREADERS

Depending on the make and model of the truck it may be necessary to install a light converter (MEYER PART #56-0028). Converter will allow signal lights and brake lights to operate according to DOT lighting standard. Call factory for more information.

USE OF SAFETY CHAIN

⚠ CAUTION: A SAFETY CHAIN MUST BE INSTALLED TO RETAIN THE CONNECTION BETWEEN TRACTOR (OR OTHER TOWING VEHICLE) AND SPREADER WHENEVER TRAVELING ON PUBLIC ROADS IN CASE THE HITCH CONNECTION WOULD SEPARATE. A SUGGESTED ATTACHMENT IS ILLUSTRATED ON FIGURE 3.

The chain must be strong enough to hold the weight of the loaded spreader (See table on page 9). If using a grab hook at the end(s) of the chain to secure the chain to itself, a hook latch must be installed.

The length of the safety chain is not to be any longer than necessary to turn without interference. If any chain links or attachment hardware are broken or stretched, repair before using. Store chain so it does not corrode or become damaged. Do not use this chain for other implements because the strength and length of the chain may not be adequate. Identify this chain for use on this particular spreader. Do not use the intermediate support as the attaching point.



FIGURE 3. SAFETY CHAIN INSTALLATION

FREEZING WEATHER OPERATION

Allow spreader to completely empty last of manure contents and disengage tractor PTO. Shut off tractor, remove the ignition key and allow all movement to stop before attempting to clean the spreader.

 **WARNING: DO NOT CLEAN, ADJUST OR LUBRICATE WHILE SPREADER IS IN MOTION. FAILURE TO HEED MAY RESULT IN SERIOUS PERSONAL INJURY OR DEATH.**

Scrape clean any remaining manure from inside the rear of spreader. Clean all manure from ends of augers, flow control rear gate and spinners.

 **WARNING: MAKE CERTAIN EVERYONE IS CLEAR OF THE SPREADER BEFORE APPLYING POWER. FAILURE TO HEED MAY RESULT IN SERIOUS PERSONAL INJURY OR DEATH.**

Slowly engage the PTO. Operate the spreader several minutes to clean manure scrapings and to allow any remaining manure and the spreader to freeze dry. Hydraulically run the flow control rear gate up and down to clean gate slide guides. Park spreader with flow control rear gate approximately halfway open.

Before loading in freezing weather, make sure augers and spinners are free to rotate, and the flow control rear gate moves freely up and down.

 **DANGER: KEEP AWAY AND KEEP OTHERS CLEAR OF ROTATING SPINNERS AT REAR OF SPREADER. SERIOUS INJURY OR AMPUTATION COULD RESULT. FAILURE TO HEED MAY RESULT IN PERSONAL INJURY OR DEATH.**

OPERATION

LOADING

⚠ CAUTION: TO PREVENT DAMAGE TO AUGERS, SPINNERS, AND DRIVE LINES, FOREIGN OBJECTS (STONES, CONCRETE, TIMBER, METAL OR LARGE FROZEN CHUNKS OF MANURE) SHOULD NEVER BE LOADED INTO THE SPREADER.

⚠ DANGER: NEVER ENTER THE SPREADER BOX FOR ANY REASON WITHOUT FIRST DISCONNECTING PTO SHAFT FROM TRACTOR. DO NOT ALLOW OTHERS IN THE BOX. ROTATING AUGERS CAN CRUSH AND DISMEMBER. FAILURE TO HEED MAY RESULT IN SERIOUS PERSONAL INJURY OR DEATH.

⚠ CAUTION: DO NOT USE JACK EXCEPT WHEN SPREADER IS EMPTY. JACK WILL NOT SUPPORT ADDED WEIGHT. UNBALANCED WEIGHT MAY RESULT IN UNEXPECTED “TIP UP” OF SPREADER.

Before loading, especially in freezing weather, make sure the augers and spinners are free to rotate and the flow control rear gate moves freely up and down.

Check and be sure that the flow control rear gate is completely closed before loading.

When the spreader is parked for loading, shift the tractor to neutral or park and set the brakes. The moisture content of the manure will determine how full the spreader can be loaded so that no manure spills out.

You will probably be able to load solid manure at least level with the top of the box while semi-liquid and liquid manure will have to be less than full in the spreader box. It is unlawful to allow manure to splash or leak onto public roads.

A liquid manure kit is available for installation around the top of the box on your spreader which will aid in the containment of liquids.

UNLOADING

⚠ WARNING: MAKE CERTAIN EVERYONE IS CLEAR OF SPREADER BEFORE APPLYING POWER. FAILURE TO HEED MAY RESULT IN SERIOUS PERSONAL INJURY OR DEATH.

⚠ DANGER: KEEP AWAY AND KEEP OTHERS CLEAR OF ROTATING SPINNERS AT REAR OF SPREADER. SERIOUS INJURY OR AMPUTATION COULD RESULT. FAILURE TO HEED MAY RESULT IN SERIOUS PERSONAL INJURY OR DEATH.

When you are ready to begin spreading application on the field, open the hydraulic flow control rear gate and slowly engage the tractor PTO clutch. This can be done while traveling forward to avoid a heavier application of liquid manure at the edge of the field than desired.

For liquid and semi-liquid manure, the application rate can be controlled by the amount the flow control rear gate is opened. The gate indicator on the front of the box will provide a ready reference for the amount of opening. For solid manure (dry, pen-packed or manure containing long straw or hay) the flow control rear gate **MUST** be completely open since this material is not free flowing.

VERY IMPORTANT: THIS MACHINE IS NOT INTENDED TO BE A BALE GRINDER, HAY CHOPPER OR BEDDING MACHINE. LONG HAY OR STRAW MUST CONTAIN MANURE IN ORDER TO BE SPREAD. FAILURE TO COMPLY MAY DAMAGE THE DRIVETRAIN AND VOID THE WARRANTY.

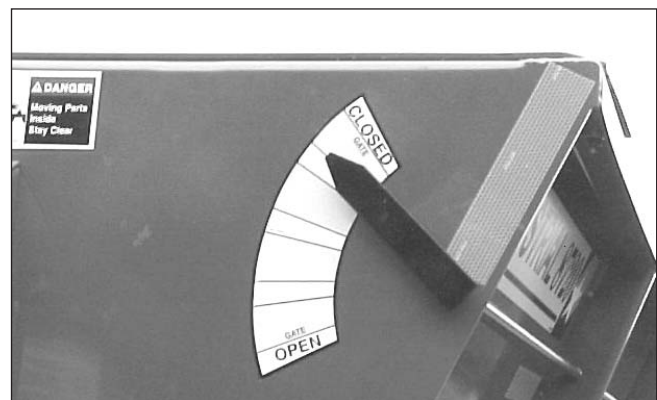

FIGURE 4. FLOW CONTROL GATE INDICATOR

The rear spinners have been designed and tested to provide the best spread pattern for most liquids and semi solid manure. However, the pattern will vary for each specific condition. The factors that contribute most to differing patterns will be moisture content and the amount and length of bedding material. For most typical conditions, the spread pattern should be uniform and about 15 ft. wide. When this is the case, plan your spreading patterns so you do not have to travel over previously spread manure which will be slippery, resulting in poor traction. Traction on wet grass is also poor. When the resulting pattern may require that you overlap during spreading, use precautions on slopes and hills where you could experience a loss of traction by traveling over ground with previously spread manure.

NOTE: Further control of the application rate is possible by the relationship of tractor engine speed to ground speed (transmission gear selection). For optimum, trouble-free performance it is recommended to operate at or near engine PTO speed.

When the spreader is empty, idle the tractor and stop the PTO. Close the flow control rear gate.

 **WARNING: NEVER OPERATE PTO ABOVE ITS NORMAL 540 or 1000 RPM RATING. TRACTOR'S PTO MUST MATCH IMPLEMENT PTO.**

NOTE: Failure to idle the tractor before disengaging the PTO will cause roller chain over-running and damage to the chain tighteners.

NOTE: Maximum life of the PTO shaft universal joints will result if you stop the PTO while making turns at the end of the field.

 **CAUTION: DO NOT EXCEED THE MAXIMUM 80° TURNING ANGLE ON THE CONSTANT VELOCITY PTO DRIVELINE. EXCEEDING THE TURNING ANGLE WILL DAMAGE THE CONSTANT VELOCITY "CENTER HOUSING" AND WILL EXERT EXCESSIVE PRESSURES ON THE PTO INPUT CENTER SHAFT AND RELATED BEARINGS.**

SHEAR SPROCKET INSTRUCTIONS

The Meyer Spreader you have received has been equipped with a shear sprocket design on the main auger drive sprockets. The augers are being driven by two allen head grade 8 bolts. The design is such that if the bolts are sheared another set of holes to install new shear bolts will always be accessible without turning over the machine.

 **DANGER: AT NO TIME SHOULD INSTALLATION BE DONE WITH ANYONE ON THE TRACTOR. SHUT THE TRACTOR OFF, REMOVE THE KEY AND DISCONNECT THE DRIVE LINE BEFORE DOING ANY SERVICE ON THIS MACHINE. SERIOUS INJURY OR DEATH MAY OCCUR IF SAFETY IS NOT FOLLOWED.**

The plate sprocket is set up with the initial drive bolts being 9/16" diameter (Prior to serial # S1088865/8720287), 5/8" diameter (Serial # S1088865/8720287 and later). Install the new bolts in the proper way as to drive off of **THE HEAD** of the bolt, not on the nut.

Part #	Description
831-5618-1.75	9/16-20x1-3/4" Allen Head Cap Bolt
831-5618-2.25	9/16-20x2-1/4" Allen Head Cap Bolt
884-5618	9/16-20 Top Locknut Grade 8
831-6318-1.75	5/8-18x1-3/4" Allen Head Cap Bolt
884-6318	5/8-18 Top Locknut Grade 8
910-0100	140B35 Shear Sprocket Assembly Complete

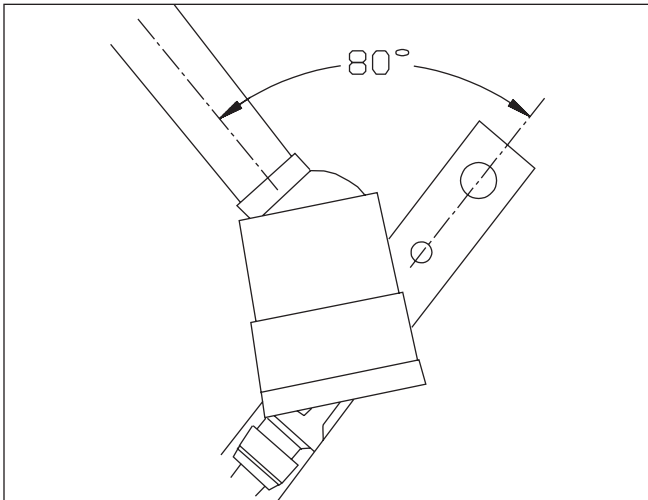

STORAGE AFTER USE

⚠ WARNING: DISCONNECT PTO DRIVE SHAFT AND HYDRAULIC HOSES BEFORE CLEANING, ADJUSTING, OR SERVICING THIS MACHINE. FAILURE TO HEED MAY RESULT IN SERIOUS PERSONAL INJURY OR DEATH.

Before storing this spreader for an extended period of time perform the following:

Allow the spreader to completely clean out the last load. Thoroughly hose off all manure from the outside of the spreader and the inside of the box, particularly getting the flow control rear gate mechanism clean. The wash water can be drained into your manure storage pit, or if the gate is left closed, the water can be spread on the field. After cleaning, completely lubricate the entire spreader to exclude moisture from bearings and to prevent condensation from forming during storage. See "Lubrication" pages 20 and 21.

Oil the roller chains by running the spreader at idle speed while opening the rear gate to activate the automatic oiler system. It is also a good time to inspect all adjustments and check for parts that need repair or replacement. Performing these tasks now will guarantee that the spreader is ready for use at the beginning of the next season.

PTO DRIVELINE

! WARNING: BEFORE ATTEMPTING TO OPERATE THIS SPREADER, READ AND STUDY ALL SAFETY INFORMATION. IN ADDITION, MAKE SURE THAT EVERY INDIVIDUAL WHO OPERATES OR WORKS WITH THE SPREADER, WHETHER FAMILY MEMBER OR EMPLOYEE, IS FAMILIAR WITH THESE SAFETY PRECAUTIONS.

! WARNING: DISCONNECT PTO DRIVE SHAFT AND HYDRAULIC HOSES (RELIEVE HYDRAULIC PRESSURE) BEFORE CLEANING, ADJUSTING, LUBRICATING OR SERVICING THIS SPREADER. FAILURE TO HEED MAY RESULT IN SERIOUS PERSONAL INJURY OR DEATH.

The Meyer 8720/8865 Industrial Series Spreader is equipped with a cutout type clutch on the implement half of the PTO driveline. The clutch is designed to limit the amount of torque transferred to the machine through the driveline. If excessive torque is developed the clutch will disengage. A loud ratcheting sound will be heard and the transfer of power to the machine will be disrupted. To reengage the machine simply shut down the PTO and allow the driveline to come to a stop. The PTO can then be reengaged to restart the spreader. The cutout clutch will either reengage upon shut down of the PTO or just before it comes to a complete stop.

The cutout clutch will disengage if start up is done in an abrupt or reckless manner. It also will disengage from foreign materials entering the spinner area of the spreader. It may also be possible to disengage the clutch by overloading or flooding the spinners with free flowing or liquid manure. If PTO clutch fails to reengage it will be necessary to remove the foreign object from the spreader before restarting. **THERE IS NO FIELD ADJUSTMENT ON THE CUTOUT CLUTCH.**

! DANGER: NEVER ENTER THE SPREADER BOX FOR ANY REASON WITHOUT FIRST STOPPING THE TRACTOR, SHUTTING THE TRACTOR OFF AND REMOVING THE KEY, SETTING THE PARKING BRAKE AND DISCONNECTING THE PTO DRIVELINE FROM THE TRACTOR. DO NOT ALLOW OTHERS IN THE BOX. ROTATING AUGERS CAN CRUSH AND DISMEMBER. FAILURE TO HEED MAY RESULT IN SERIOUS PERSONAL INJURY OR DEATH.

DRIVELINE ATTACHMENT

The cutout clutch end of the PTO driveline must always be attached to the implement. The PTO driveline is equipped with a 1 3/8-6 spline on the implement half for attaching to the spreader. Remove the M17-hexagon bolt from the splined hub and slide the PTO onto the implement splined input shaft. Install the hexagon bolt through the hub being sure the bolt is falling into the groove on the splined shaft. Torque tight using a metric size M17 6-point socket and torque down to 75 ft. lbs. **A M17 6-POINT METRIC SOCKET MUST BE USED AS ROUNDING OF HEXAGON BOLT AND INACCURACY OF TORQUE SETTINGS COULD OCCUR.**

If removal of the M-17 hexagon bolt is necessary, use the same M-17 6-point socket and loosen bolt 1/2 turn. Insert a 1/4" drift punch in the hole on the opposite side of the hexagon bolt and tap to loosen the seated portion of the bolt from the splined hub. Loosen in 1/2 turn increments and tapping to loosen. After bolt seat has been released, remove the bolt. If bolt is not unseated, damage to the hexagon bolt will occur.

Attach the shield safety chain to a suitable area on the spreader, preferably to the implement PTO steel shield.

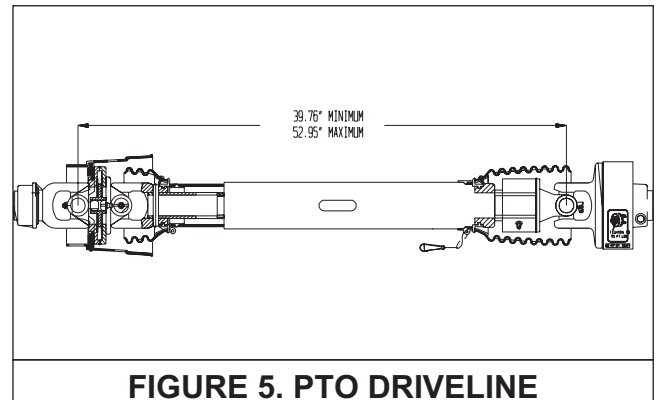

PTO SETUP

! DANGER: NEVER ATTEMPT TO PERFORM ANY WORK ON THIS MACHINE FOR ANY REASON WITHOUT FIRST STOPPING THE TRACTOR, SHUTTING THE TRACTOR OFF AND REMOVING THE KEY, SETTING THE PARKING BRAKE AND DISCONNECTING THE PTO DRIVELINE FROM THE TRACTOR AND DISCONNECTING THE HYDRAULIC HOSES AND RELIEVING HYDRAULIC PRESSURE.

FAILURE TO HEED MAY RESULT IN SERIOUS PERSONAL INJURY OR DEATH.

Adjust the drawbar at 16-20" above the ground. Extend or shorten the drawbar so horizontal distance from end of tractor PTO shaft to center of hitch pin hole is 16" for 1000 RPM 1-3/8-21 spline, 20" for 1000 RPM 1-3/4-20 spline. Secure the drawbar so the hitch pin hole is located directly below the PTO driveline. PTO adapters are not recommended as damage to the driveline may occur. A hitch pin with a minimum diameter of 1-5/16" and bottom retaining pin is recommended.

AN IMPROPERLY LOCATED HITCH POINT MAY CAUSE DAMAGE TO THE UNIVERSAL JOINTS OF THE PTO DRIVE SHAFT. CONFORMING TO THE DRAWBAR AND PTO RELATIONSHIP SHOWN ON FIGURE 1, PAGE 8 WILL ENSURE THAT THE PTO DRIVESHAFT WILL NOT BECOME OVER EXTENDED. USE THE CORRECT SETTING FOR 14" - 540RPM 1 3/8-6, 16" - 1000RPM 1 3/8-21 OR 20" - 1000RPM 1 3/4-20. WITH INITIAL HOOK-UP TO YOUR NEW MEYER SPREADER TEST PTO TRAVEL BY TURNING EQUIPMENT IN BOTH DIRECTIONS OBSERVING THE MINIMUM AND MAXIMUM TRAVEL DIMENSIONS AS SHOWN PER DRAWING ON FIGURE 5, PAGE 15.

LUBRICATION

LUBRICATION

A high quality Lithium Base Grease should be used

PRIOR TO USE

Using the CV Zerk (Key #2) place 20 pumps of grease into the CV center housing. This should be done with the driveline / CV as straight as possible.

Slowly articulate the double joint through its maximum joint angle several times.

Return the CV joint to its straight position and insert additional grease into the CV Zerk (Key #2) until grease is evident around the housing and center sliding disk.

NORMAL OPERATION

Lubricate the following items after every eight (8) hours of operation. If short rows and frequent turning or other demanding conditions exist, lubricate at four (4) hour intervals.

Cross and bearings (Key #1)-Add grease until it is purged around the seals

CV center housing (Key #2)-Add grease until it is evident around the center sliding disk.

Telescoping members (Key #3)-Add grease until it adequately covers the sliding members. Take apart occasionally to make sure adequate lubrication is being added.

Shield bearings (Key #4)-Add 2-3 pumps.

FAILURE TO FREQUENTLY GREASE THE CV CENTER HOUSING AND TELESCOPING MEMBERS WILL REDUCE THE LIFE OF THE CV.

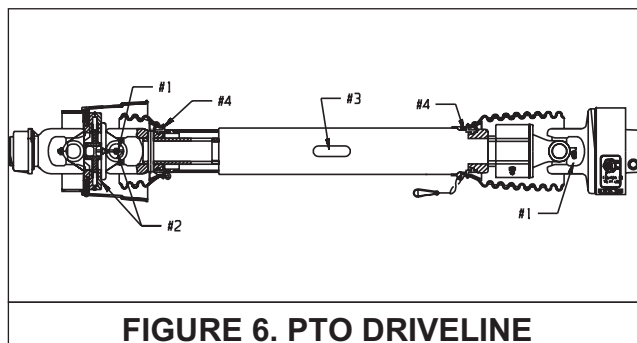

FIGURE 6. PTO DRIVELINE

MAINTENANCE INFORMATION

It is extremely important to follow the maintenance guidelines. If telescoping members become hard to slide during normal operation, it is recommended the shaft be taken apart, cleaned with solvent and recoated with grease before re-assembling. As a minimum it is important this be done after each season of use.

ADJUSTMENTS



WARNING: DISCONNECT PTO DRIVE SHAFT AND HYDRAULIC HOSES (RELIEVE HYDRAULIC PRESSURE) BEFORE CLEANING, ADJUSTING, LUBRICATING OR SERVICING THIS SPREADER. FAILURE TO HEED MAY RESULT IN SERIOUS PERSONAL INJURY OR DEATH.

FRONT DRIVE ROLLER CHAINS

There are six roller chain drives located at the front of the spreader. Regularly check that all tensioning springs are in serviceable condition for automatic roller chain tightening. Manually adjust spring tensioners (as needed) by turning double locknuts on all tensioning bolt/idler assemblies. Proper roller chain tension is when 1/4" to 1/2" deflection occurs on the slack side of the chain. Regularly re-check all roller chain tensions. Keep all roller chains tight at all times! For clarity purposes, the following illustrations detail each roller chain reduction separately.

NOTE: The side bars of the roller chains will wear into the idler nylon rollers up to the rollers of the roller chain forming grooves. These grooves will serve as a guide when the roller chain loosens due to normal use. From this point on, after tightening, the idler nylon rollers should run for hundreds of hours without any noticeable wear.

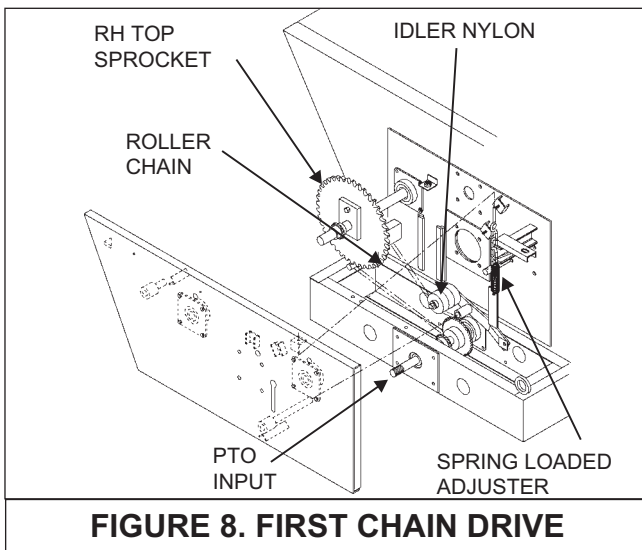

FIGURE 8. FIRST CHAIN DRIVE

The first chain drive (PTO input shaft to the large RH top sprocket, figure 8) is automatically tensioned by a spring loaded idler nylon roller. The extension spring should extend 2" from its neutral 5" total length.

Manual adjustment for the automatic tensioning idler, nylon roller assembly is located at the left rear of the spreader's front bearing mounting plate.

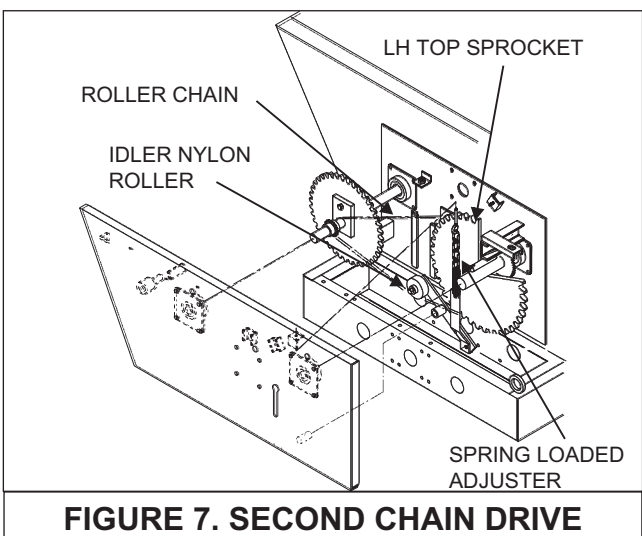

FIGURE 7. SECOND CHAIN DRIVE

The second chain drive (large RH top sprocket to the large LH top sprocket, figure 7) is automatically tensioned by a spring loaded idler nylon roller. The extension spring should extend 2" from its neutral 5" total length.

Manual adjustment for the automatic tensioning idler, nylon roller assembly is located at the left rear of the spreader's front bearing mounting plate.

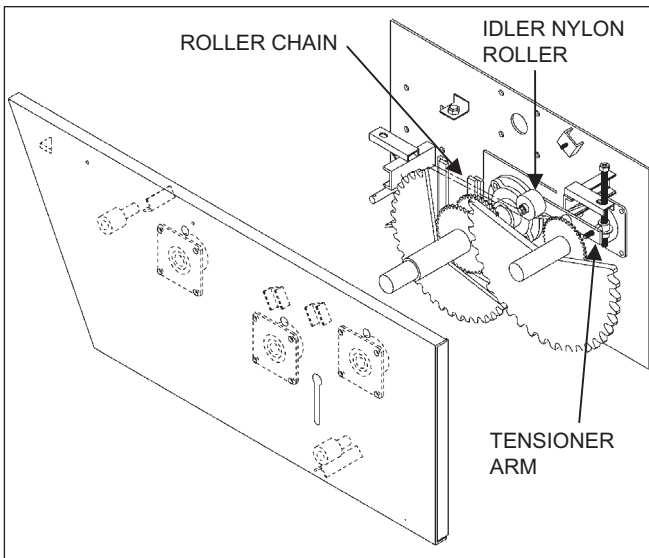

FIGURE 11 . THIRD CHAIN DRIVE

The third chain drive is automatically tensioned by a spring-loaded nylon idler roller. The compression spring should be compressed to 4.5" in length. See figure 11.

To increase tension on the automatic tightener, tighten the adjuster bolt located at the left side of the spreader.

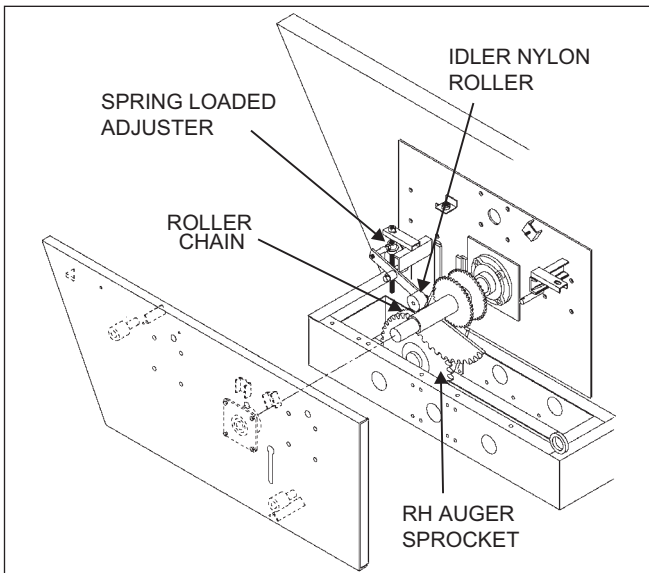

FIGURE 10. RH AUGER CHAIN DRIVE

The RH auger chain drive, figure 10, is automatically tensioned by a spring loaded idler nylon roller. The compression spring should be compressed to 4.5" in length. See figure 10.

To increase tension on the automatic tightener, tighten the adjuster bolt located at the right side of the spreader.

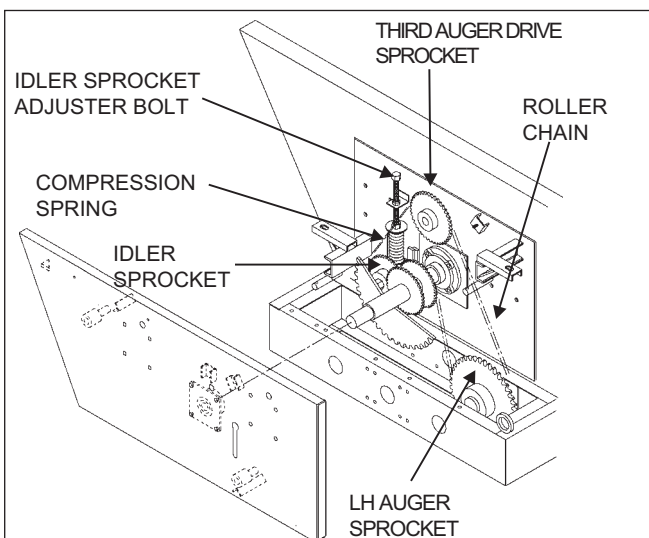

FIGURE 9. LH & THIRD AUGER CHAIN DRIVE

The LH and third auger chain drive is automatically tensioned by a spring loaded heavy compression spring and sliding idler sprocket assembly, figure 9. The heavy compression spring should be compressed to 4" in length.

Manual adjuster bolt for the automatic tensioning idler assembly is located slightly right of center on the spreader tank.

The side shaft chain drive (PTO input shaft to the side line shaft drive sprocket, figure 13) is automatically tensioned by a spring-loaded idler nylon roller. The extension spring should extend 2" from its neutral 5" total length.

Manual adjustment for the automatic tensioning idler, nylon roller assembly is located at the right rear of the spreader's front bearing mounting plate.

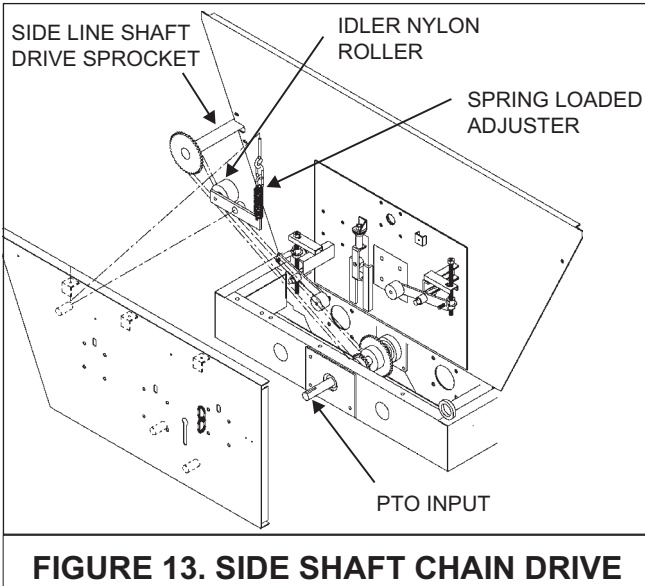

FIGURE 13. SIDE SHAFT CHAIN DRIVE

SPINNER MATERIAL GUIDES

Regularly inspect and adjust two spinner material guides located at both the left rear and right rear of the spreader. Create a 1/8-3/8" clearance between material guides and spinner teeth, figure 12. Maintain the recommended clearances for maximum spreading pattern. Adjust to prevent excessive manure build-up on material guide inner surfaces. Adjust to prevent manure chunks or foreign object lodging between material guides and spinner teeth.

NOTE: Excessive lodging can cause premature spinner tooth wear, "bent-over" or even breakage.

SHEAR ARM MATERIAL GUIDE ADJUSTMENT

Adjustment for the 1/8-3/8" clearance of each material guide to spinner tooth is made by loosening the jam nut on the linkage arm and turning the linkage arm to either move the guide in closer or out farther from the spinner teeth. After adjustment has been made for the 1/8-3/8" clearance retighten the jam nut to hold the material guide in place. Once recommended clearance is ob-

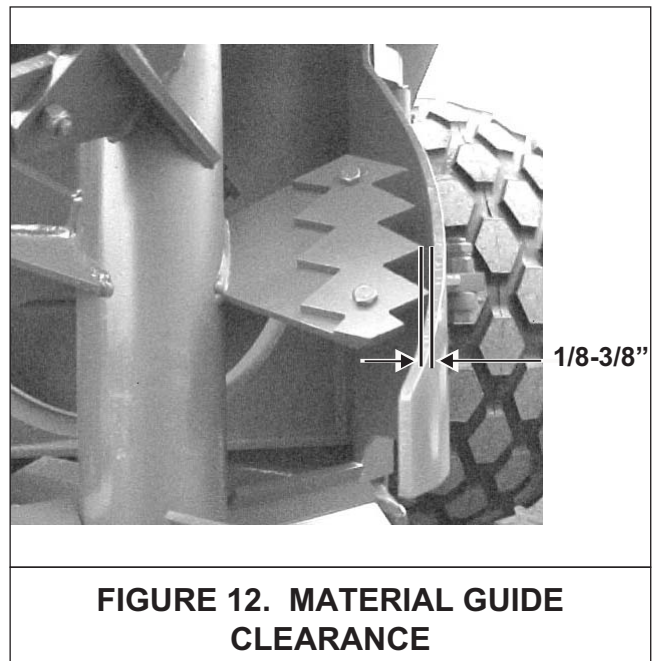

FIGURE 12. MATERIAL GUIDE CLEARANCE

tained turn spinners over by hand in the direction by which the spreader would turn to check clearance. Do not turn in the opposite direction as front chain tightener damage could occur. If foreign objects enter the spinner area the front pivot bolt on the shear arm is designed to shear. The extension spring will pull the material guide away from the spinner until the shear bolt is replaced. The 1/2-13 x 3 1/2" grade 5 replacement machine bolts are stored under the rear shield. For replacement install with 1/2" flat washer on top of shear eye and on bottom of block and tighten nylon locknut firmly.

LUBRICATION



WARNING: DISCONNECT PTO DRIVE SHAFT AND HYDRAULIC HOSES (RELIEVE HYDRAULIC PRESSURE) BEFORE CLEANING, ADJUSTING, LUBRICATING OR SERVICING THIS SPREADER. FAILURE TO HEED MAY RESULT IN SERIOUS PERSONAL INJURY OR DEATH.

DAILY LUBRICATION (every 8-12 loads)

L1 Grease (2) rear spinner lower bearings. These bearings are grease line fitted to the LR frame channel of the spreader.

L2 Oil (6) roller chain drives with automatic oiler at the front of spreader with clean 30-weight oil. The roller chains are accessible by opening the front steel shielding cover.

L3 Grease PTO Drive line (9) places with Lithium grease every 8 hours.

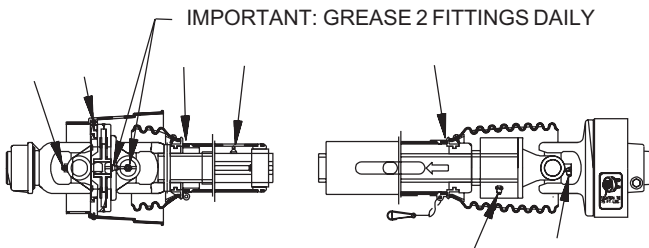

L4 Grease (7) bearings supporting the three large jack shaft reduction sprocket weldments, and the third auger drive shaft on the front drive. The zerks are accessible by the right front side grease bank and through the access holes in front plate. Be careful not to over grease.

L5 Grease (2) auger shaft bearings. These bearings are grease line fitted to the LF and RF frame channels of the spreader. Over greasing is not possible. 10-15 pumps minimum.

IMPORTANT: Check regularly for any observable lubricant leakage of the (3) gearboxes at the rear of the spreader. See L12 & L14 under *Monthly Lubrication*

WEEKLY LUBRICATION (every 25-30 loads)

L6 Grease (3) PTO input shaft bearings. These bearings are grease line fitted to the RF frame channel and the front bearing channel of the spreader.

L7 Grease (5) bearings on the RH side line shaft. The front bearing is zerk accessible through the RF steel shielding. The remaining rear bearings are located along the RH side of the spreader tank, zerks accessible through the steel shielding.

L8 Grease (2) tandem wing pivots. Effectively grease by jacking up the spreader to relieve pressure points on the pivot shaft and tandem wing collar. Over greasing is not possible.

L10 Grease (2) flow control rear gate slide guides. With the flow control rear gate opened, grease the slide guides from top side. Allow grease to lubricate flow control rear gate ends and slide guide surfaces. In freezing weather dump used motor oil down each slide guide once a week or more often if needed. Over greasing is not possible.

L11 Grease (1) integral overrunning clutch at rear of the PTO drive line. The zerk is on the yoke of the cut out clutch. Use Shell Super Duty or an equivalent lithium grease.

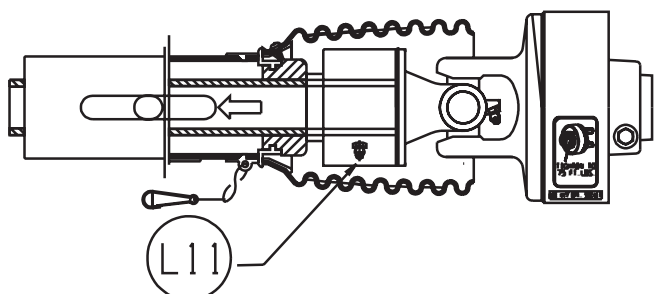

MONTHLY LUBRICATION

L12 Maintain oil level in the corner gearbox at the centerline of the input shafts. Check regularly for any observable oil leakage. If oil leakage is excessive, replace required input/output shaft oil seals. Use ONLY EP #80-90 wt. gear lube oil or an equivalent in corner box, only Lighter weight gear lube oil may be used in temperatures lower than 20°F. Change oil in the gearboxes after the first season of use and regularly thereafter.

L13 Grease (1) brass bushing supporting the rear shaft of the 3rd auger assembly. This zerk is located on the left rear corner of the tank above the inner cross brace.

L14 Maintain the lube level in the (2) spinner gearboxes at 3/4 full. Check regularly for any observable leakage. If leakage is excessive, replace required input/output shaft seals. Lubricate with Semi-Fluid, EP Lithium Base, Gear Grease.

L15 Clean and repack the wheel hubs with axle grease annually. Grease hub through zerk in hub monthly. Be careful not to over grease and force seal out of back side of hub.

L16 Oil slides on front idler tightener assembly.

L17 Grease (4) material guide pin sleeves. (2) located on each side of the spreader.

L18 Grease (2) T-post hold down sleeve zerks located above the cross channel on the underside of the spreader. A zerk is located on the front and one on the rear of the sleeve.

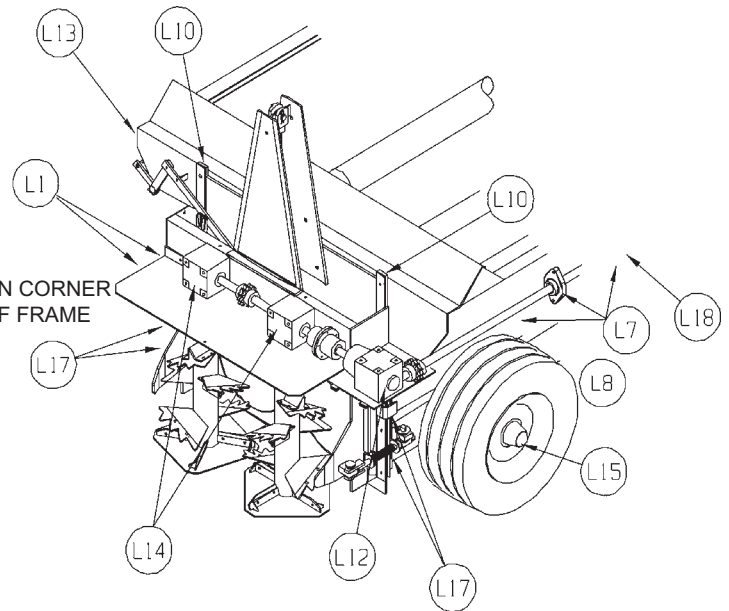
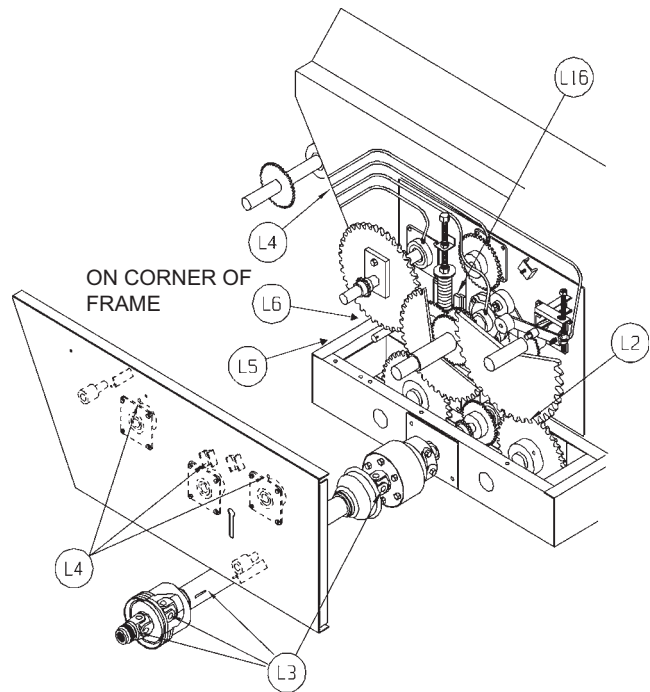

(SHIELDS REMOVED FOR ILLUSTRATIVE PURPOSES ONLY.)

REPAIR PARTS

918-0308 (STANDARD 8720) (OPTIONAL 8865) (SERIAL #SI078720288-SI088720425) (FOR EARLIER MODELS SEE PAGE 24.)
918-0408 (STANDARD 8720) (OPTIONAL 8865) (SERIAL #SI088720426 & LATER)

PTO DRIVE SHAFT-STAR PROFILE
1000 RPM 1-3/8 21 SPLINE WWE2480 (80 DEGREE C.V.)

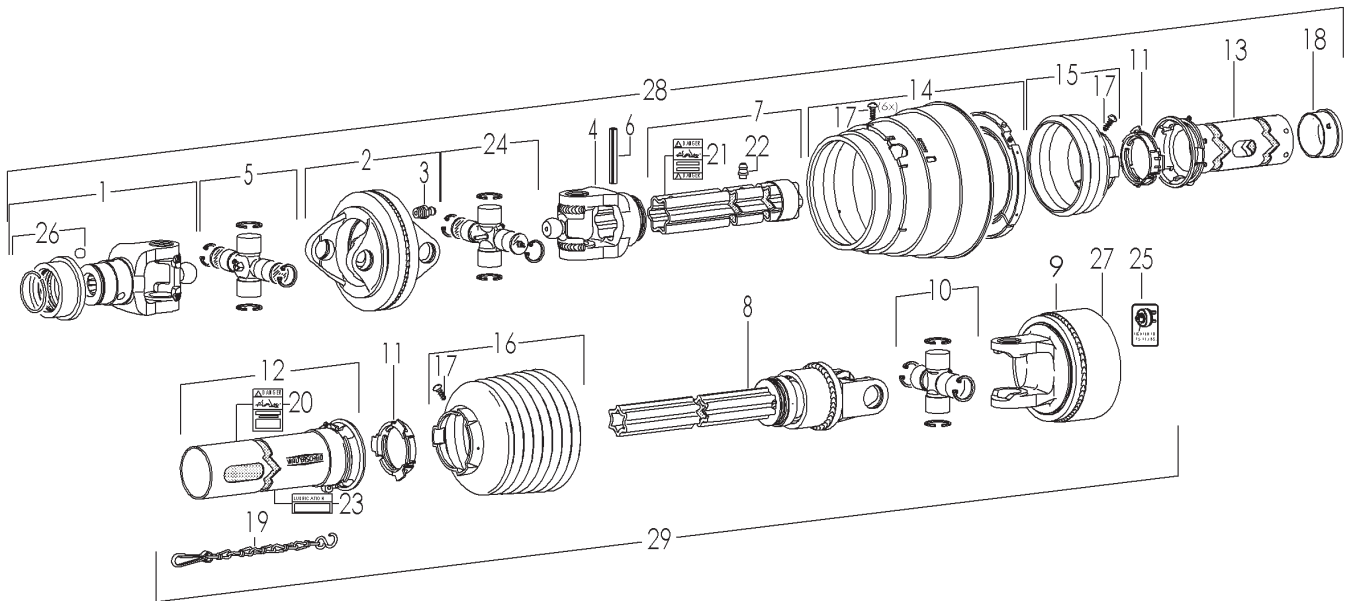

**918-0308 (STANDARD 8720) (OPTIONAL 8865) (SERIAL #SI078720288-SI088720425)
 (FOR EARLIER MODELS SEE PAGE 24.)
 918-0408 (STANDARD 8720) (OPTIONAL 8865) (SERIAL #SI088720426 & LATER)
 PTO DRIVE SHAFT-STAR PROFILE
 1000 RPM 1-3/8 21 SPLINE WWE2480 (80 DEGREE C.V.)**

KEY	PART NO.	DESCRIPTION
1	918-0208-1-1	Yoke 1-3/8"-21 Splined Assembly
2	918-0208-1-3	Double Yoke
3	918-0208-1-2	Grease Zerk in Item 2 & 8
4	918-0308-1-1	Inboard Yoke
5	918-0208-1-5	Cross and Bearing Kit
6	918-0208-1-6	Spring Pin 10 x 80
7	918-0308-1-2	Profile S5 and Sleeve Welded Assy.
8	918-0308-2-1	Overrunning Clutch & S4LGA Profile Assy.
9	918-0308-2-2	Cut Out Clutch (Prior to serial #SI088720425)
	918-0410-2-1	Cut Out Clutch (Serial #SI088720426 & Later)
10	918-0208-2-1	Cross and Bearing Kit
11	918-0208-2-4	Bearing Ring SC25
12	918-0308-2-3	Outer Shield Tube OVL
13	918-0308-2-4	Inner Shield Tube Round
14	918-0308-1-3	CV Cone and Bearing Assy.
15	918-0308-1-4	Shield Cone 3-Rib
16	918-0308-2-5	Shield Cone 8-Rib
17	918-0208-2-9	Screw-In Item 14,15 & 16

KEY	PART NO.	DESCRIPTION
18	918-0208-1-11	Support Bearing
19	918-0208-2-7	Safety Chain
20	918-0208-2-8	Decal Outer-In Item 12
21	918-0208-1-10	Decal Inner-In Item 7
22	918-0208-1-12	Zerk-In Item 7
23	918-0308-2-6	Lubrication Decal
24	918-0208-1-13	Cross and Bearing Kit
25	918-0208-2-10	Decal-K64
26	918-0208-1-1-1	Assembly Collar Kit (Inc. Ring, Collar & Balls)
27	918-0208-2-3-1	Clamp Cone Locking Pin (Prior to serial #SI088720425)
	918-0410-2-1-1	Clamp Cone Locking Pin (Serial #SI088720426 & Later)
28	918-0308-1	1-3/8-21 Spline Tractor Half Assy.
29	918-0308-2	1000 RPM Implement 1/2 Assy. (Prior to serial #SI088720425)
	918-0410-2	1000 RPM Implement 1/2 Assy. (Serial #SI088720426 & Later)

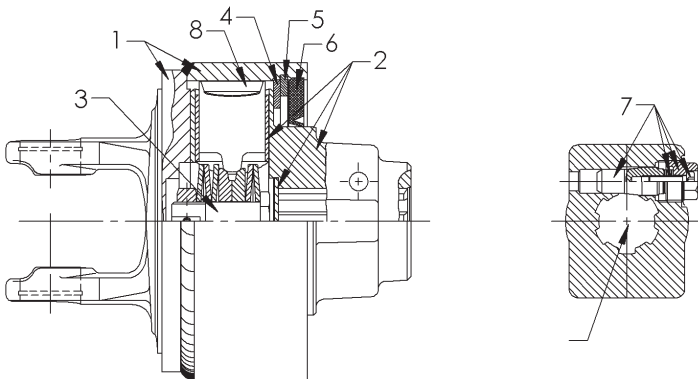

KEY	PART NO.	DESCRIPTION
1	918-0308-2-2-1	Housing
2	918-0308-2-2-2	Hub (Prior to serial #SI088720425)
	618-0003-2-1	Hub (Serial #SI088720426 & Later)
3	918-0308-2-2-3	Spring Pack
4	918-0208-2-3-5	Washer
5	918-0208-2-3-6	Retaining Ring
6	918-0208-2-3-7	Sealing Ring
	918-0208-2-3-1	Clamp Cone Locking Pin (Prior to serial #SI088720425)
	918-0410-2-1-1	Clamp Cone Locking Pin (Serial #SI088720426 & Later)
8	918-0308-2-2-4	Cam
NS	918-0208-2-3-9	Bushing-In Item #2
NS	918-0208-2-3-11	Shim Kit

918-0208
PTO DRIVE SHAFT ASSEMBLY
1000 RPM-21 SPLINE / 1-3/8" YOKE WWE2480 (80 DEGREE C.V.)

USED PRIOR TO SERIAL #SI078720287.
FOR LATER MODELS SEE PAGE 22.

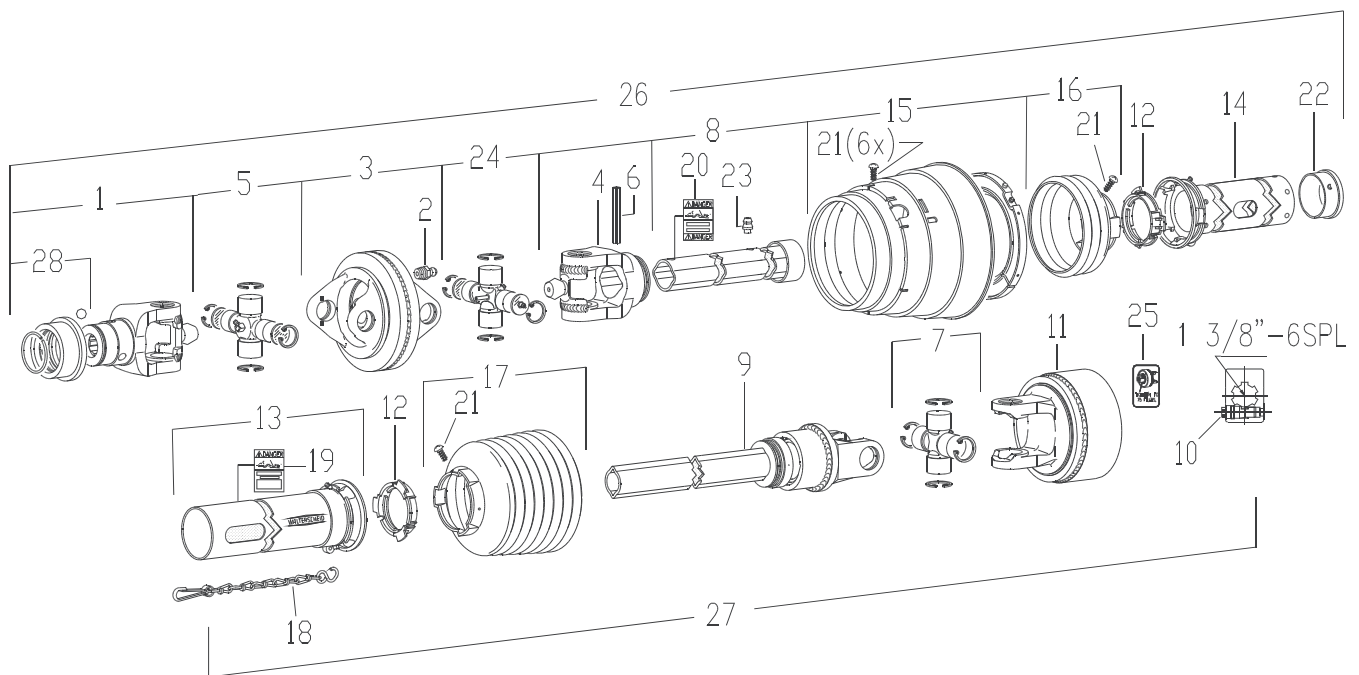

918-0208
PTO DRIVE SHAFT ASSEMBLY
1000 RPM-21 SPLINE / 1-3/8" YOKE WWE2480 (80 DEGREE C.V.)

KEY	PART NO.	DESCRIPTION
1	918-0208-1-1	Yoke 1-3/8"-21 Splined Assembly
2	918-0208-1-2	Grease Zerk in item 3
3	918-0208-1-3	Double Yoke
4	918-0208-1-4	Inboard Yoke
5	918-0208-1-5	Cross and Bearing Kit
6	918-0208-1-6	Spring Pin 10 x 80
7	918-0208-2-1	Cross and Bearing Kit
8	918-0208-1-14	Profile and Sleeve Wa
9	918-0208-2-2	Overrunning Clutch & 1bGA Profile Assy.
10	918-0208-2-3-1	Clamping Cone Bolt (Included in Item 11)
11	918-0208-2-3	Cut Out Clutch
12	918-0208-2-4	Bearing Ring SC25
13	918-0208-2-5	Outer Shield Tube OVL
14	918-0208-1-7	Inner shield Tube Round
15	918-0208-1-8	CV Cone & Bearing Assy.
16	918-0208-1-9	Shield Cone 3 Rib
17	918-0208-2-6	Shield Cone 8 Rib

KEY	PART NO.	DESCRIPTION
18	918-0208-2-7	Safety Chain
19	918-0208-2-8	Decal Out-In Item 13
20	918-0208-1-10	Decal In-In Item 8
21	918-0208-2-9	Screw-In Item 15,16 & 17
22	918-0208-1-11	Support Bearing
23	918-0208-1-12	Zerk-In Item 8
24	918-0208-1-13	Cross and Bearing Kit
25	918-0208-2-10	Decal-K64
26	918-0208-1	1-3/8-21 Spline Tractor Half Assembly
27	918-0208-2	1000 RPM Cutout Clutch Implement Half Assembly
28	918-0208-1-1-1	AS-Lock Kit For Item 1 (Inc. Ring, Collar & Balls)

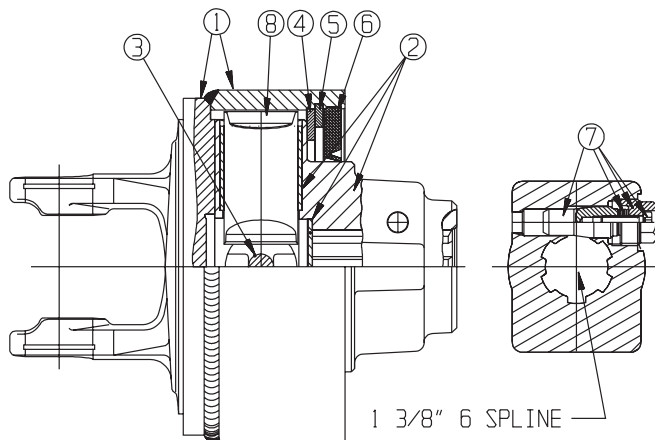

KEY	PART NO.	DESCRIPTION
1	918-0208-2-3-2	Housing
2	918-0208-2-3-3	Hub
3	918-0208-2-3-4	Spring Pack
4	918-0208-2-3-5	Washer
5	918-0208-2-3-6	Retaining Ring
6	918-0208-2-3-7	Sealing Ring
7	918-0208-2-3-1	Clamp Cone Assembly
8	918-0208-2-3-8	Cam
NS	918-0208-2-3-9	Bushing - In Item #2
NS	918-0208-2-3-11	Shim Kit

**918-0310 (OPTIONAL 8720) (STANDARD 8865) (SERIAL
 #SI078720288-SI088720425) (FOR EARLIER MODELS SEE PAGE 28.)
 918-0410 (OPTIONAL 8720) (STANDARD 8865) (SERIAL # SI088720426 & LATER)
 PTO DRIVE SHAFT-STAR PROFILE
 1000 RPM 1-3/4 20 SPLINE WWE2480 (80 DEGREE C.V.)**

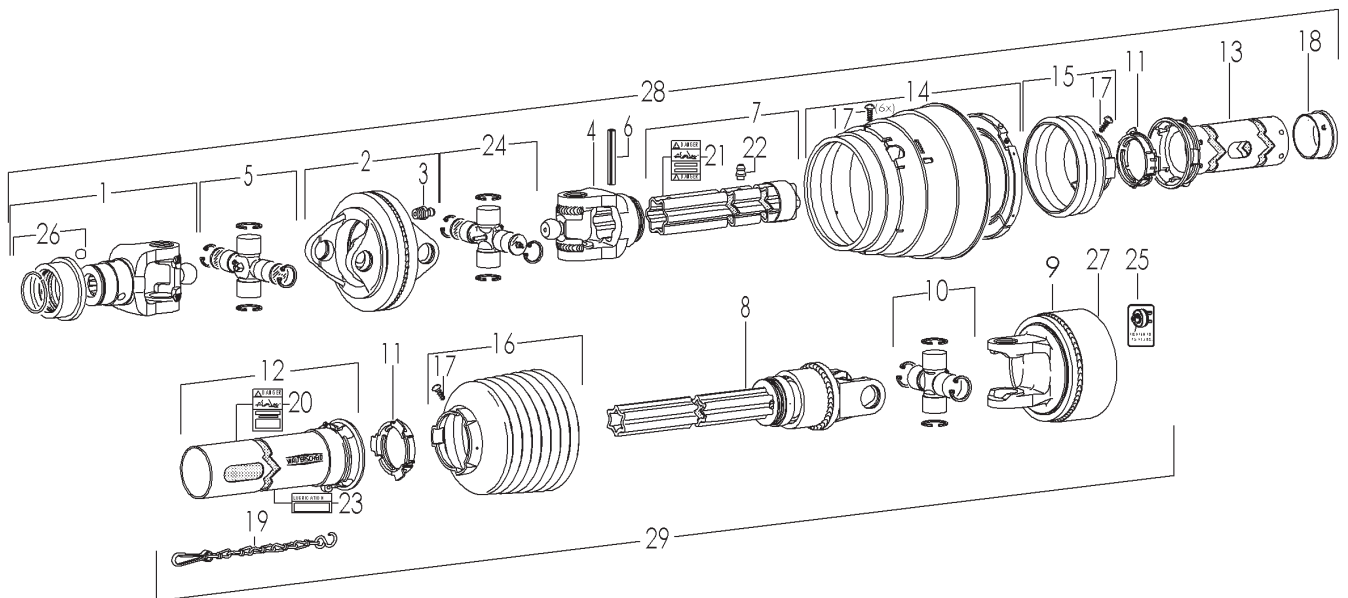

**918-0310 (OPTIONAL 8720) (STANDARD 8865) (SERIAL #SI078720288-SI088720425)
(FOR EARLIER MODELS SEE PAGE 28.)**

**918-0410 (OPTIONAL 8720) (STANDARD 8865) (SERIAL #SI SI088720426 & LATER)
PTO DRIVE SHAFT-STAR PROFILE**

1000 RPM 1-3/4 20 SPLINE WWE2480 (80 DEGREE C.V.)

KEY	PART NO.	DESCRIPTION
1	918-0210-1-1	Yoke 1-3/4"-20 Splined Assembly
2	918-0208-1-3	Double Yoke
3	918-0208-1-2	Grease Zerk in Item 2 & 8
4	918-0308-1-1	Inboard Yoke
5	918-0208-1-5	Cross and Bearing Kit
6	918-0208-1-6	Spring Pin 10 x 80
7	918-0308-1-2	Profile S5 and Sleeve Welded Assy.
8	918-0308-2-1	Overrunning Clutch & S4LGA Profile Assy.
9	918-0308-2-2	Cut Out Clutch (Prior to serial #SI088720425)
	918-0410-2-1	Cut Out Clutch (Serial #SI088720426 & Later)
10	918-0208-2-1	Cross and Bearing Kit
11	918-0208-2-4	Bearing Ring SC25
12	918-0308-2-3	Outer Shield Tube OVL
13	918-0308-2-4	Inner Shield Tube Round
14	918-0308-1-3	CV Cone and Bearing Assy.
15	918-0308-1-4	Shield Cone 3-Rib
16	918-0308-2-5	Shield Cone 8-Rib
17	918-0208-2-9	Screw-In Item 15,16 & 17
18	918-0208-1-11	Support Bearing

KEY	PART NO.	DESCRIPTION
19	918-0208-2-7	Safety Chain
20	918-0208-2-8	Decal Outer-In Item 12
21	918-0208-1-10	Decal Inner-In Item 7
22	918-0208-1-12	Zerk-In Item 7
23	918-0308-2-6	Lubrication Decal
24	918-0208-1-13	Cross and Bearing Kit
25	918-0208-2-10	Decal-K64
26	918-0210-1-1-1	Assembly Collar Kit (Inc. Ring, Collar & Balls)
27	918-0208-2-3-1	Clamp Cone Locking Pin (Prior to serial #SI088720425)
	918-0410-2-1-1	Clamp Cone Locking Pin (Serial #SI088720426 & Later)
28	918-0310-1	1-3/4-20 Spline Tractor Half Assy.
29	918-0308-2	1000 RPM Implement 1/2 Assy. (Prior to serial #SI088720425)
	918-0410-2	1000 RPM Implement 1/2 Assy. (Serial #SI088720426 & Later)

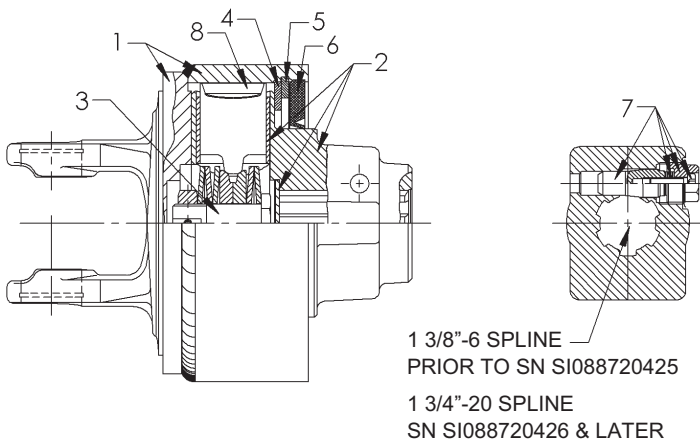

KEY	PART NO.	DESCRIPTION
1	918-0308-2-2-1	Housing
2	918-0308-2-2-2	Hub (Prior to serial #SI088720425)
	618-0003-2-1	Hub (Serial #SI088720426 & Later)
3	918-0308-2-2-3	Spring Pack
4	918-0208-2-3-5	Washer
5	918-0208-2-3-6	Retaining Ring
6	918-0208-2-3-7	Sealing Ring
7	918-0208-2-3-1	Clamp Cone Locking Pin (Prior to serial #SI088720425)
	918-0410-2-1-1	Clamp Cone Locking Pin (Serial #SI088720426 & Later)
8	918-0308-2-2-4	Cam
NS	918-0208-2-3-9	Bushing-In Item #2
NS	918-0208-2-3-11	Shim Kit

918-0210
PTO DRIVE SHAFT ASSEMBLY
1000 RPM-20 SPLINE / 1-3/4" YOKE WWE2480 (80 DEGREE C.V.)

USED PRIOR TO SERIAL #SI078720287.
 FOR LATER MODELS SEE PAGE 26.

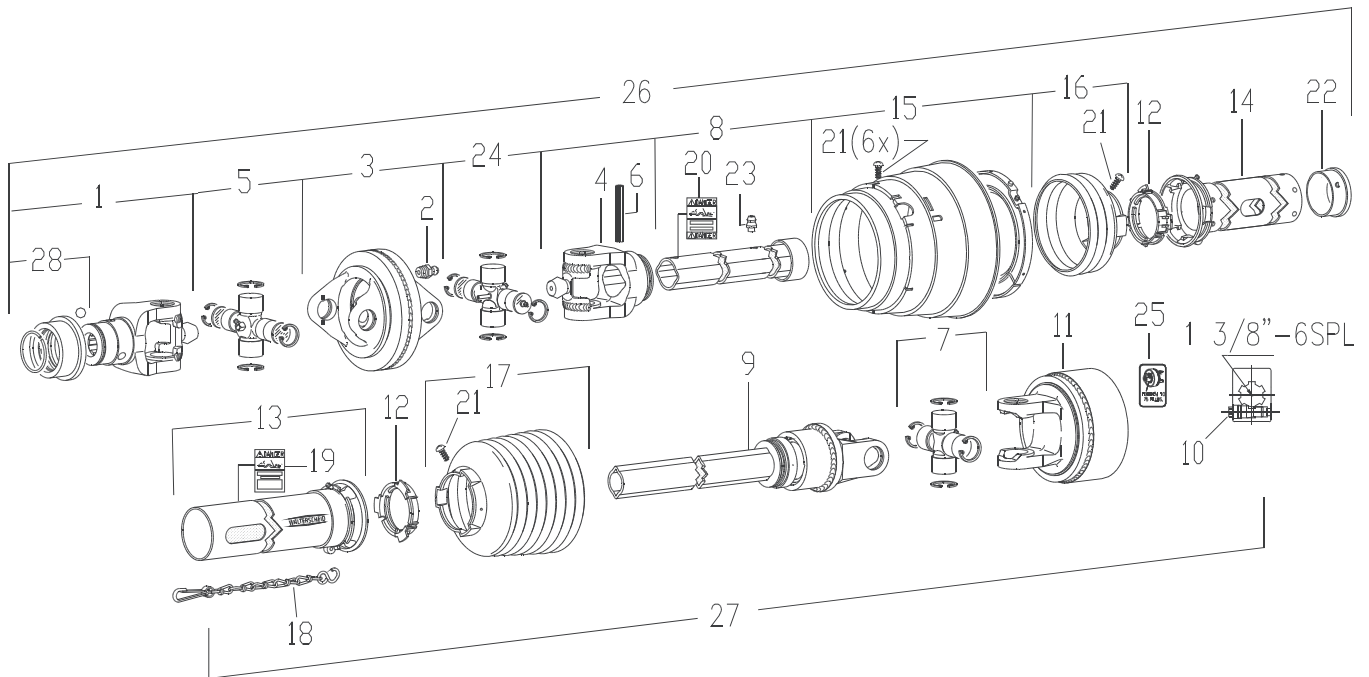

918-0210
PTO DRIVE SHAFT ASSEMBLY
1000 RPM-20 SPLINE / 1-3/4" YOKE WWE2480 (80 DEGREE C.V.)

KEY	PART NO.	DESCRIPTION
1	918-0210-1-1	Yoke 1-3/4"-20 Splined Assembly
2	918-0208-1-2	Grease Zerk in item 3
3	918-0208-1-3	Double Yoke
4	918-0208-1-4	Inboard Yoke
5	918-0208-1-5	Cross and Bearing Kit
6	918-0208-1-6	Spring Pin 10 x 80
7	918-0208-2-1	Cross and Bearing Kit
8	918-0208-1-14	Profile and Sleeve Wa
9	918-0208-2-2	Overrunning Clutch & 1bGA Profile Assy.
10	918-0208-2-3-1	Clamping Cone Bolt (Included in Item 11)
11	918-0208-2-3	Cut Out Clutch
12	918-0208-2-4	Bearing Ring SC25
13	918-0208-2-5	Outer Shield Tube OVL
14	918-0208-1-7	Inner shield Tube Round
15	918-0208-1-8	CV Cone & Bearing Assy.
16	918-0208-1-9	Shield Cone 3 Rib

KEY	PART NO.	DESCRIPTION
17	918-0208-2-6	Shield Cone 8 Rib
18	918-0208-2-7	Safety Chain
19	918-0208-2-8	Decal Out-In Item 13
20	918-0208-1-10	Decal In-In Item 8
21	918-0208-2-9	Screw-In Item 15,16 & 17
22	918-0208-1-11	Support Bearing
23	918-0208-1-12	Zerk-In Item 8
24	918-0208-1-13	Cross and Bearing Kit
25	918-0208-2-10	Decal-K64
26	918-0210-1	1-3/4-20 Spline Tractor Half Assembly
27	918-0208-2	1000 RPM Cutout Clutch Implement Half Assembly
28	918-0210-1-1-1	AS-Lock Kit For Item 1 (Inc. Ring, Collar & Balls)

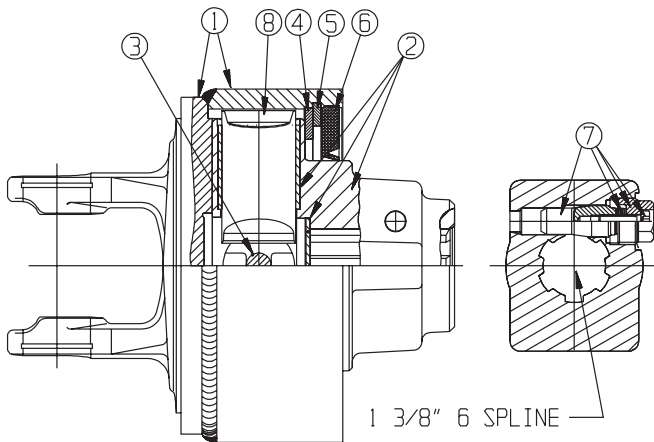

KEY	PART NO.	DESCRIPTION
1	918-0208-2-3-2	Housing
2	918-0208-2-3-3	Hub
3	918-0208-2-3-4	Spring Pack
4	918-0208-2-3-5	Washer
5	918-0208-2-3-6	Retaining Ring
6	918-0208-2-3-7	Sealing Ring
7	918-0208-2-3-1	Clamp Cone Assembly
8	918-0208-2-3-8	Cam
NS	918-0208-2-3-9	Bushing - In Item #2
NS	918-0208-2-3-11	Shim Kit

FIRST REDUCTION & SPINNER DRIVE

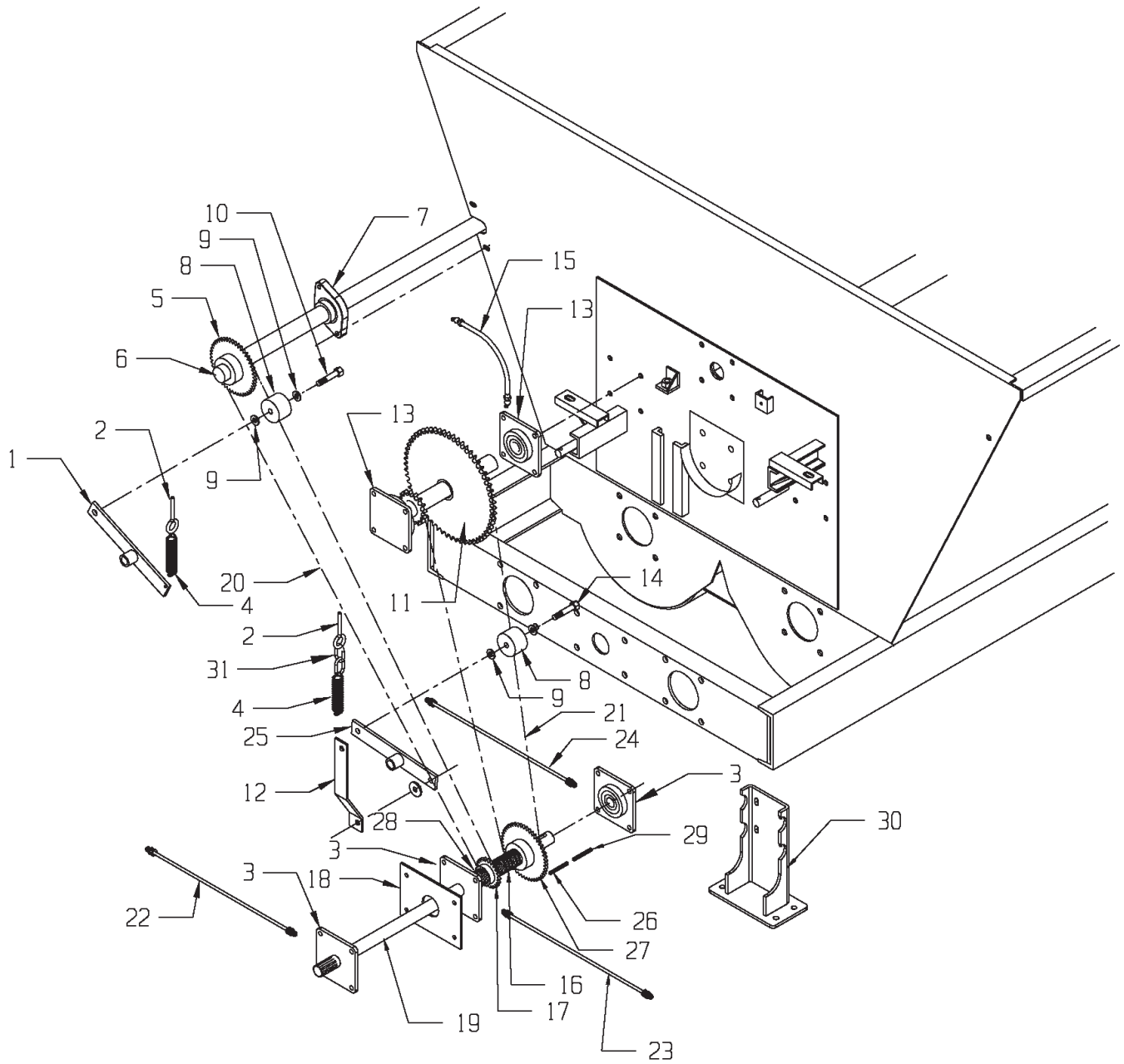

FIRST REDUCTION & SPINNER DRIVE

KEY	PART NO.	DESCRIPTION	QTY
1	925-3720	Tightener Arm Assembly, Spinner Drive	1
2	933-3804	Eyebolt, 5/16 x 5" / 4" Thread Length	1
3	914-3602	1-1/2" 4-Bolt Bearing (Prior to serial #SI088720425)	3
	914-3819	1-3/4" 4-Bolt Bearing (Serial #SI088720426 & Later)	3
4	929-0003	Extension Spring	1
5	910-0092	80B15 Sprocket Side Shaft to Spinner Drive (Clamp Style)	1
6	923-3754	Front Side Shaft 121-3/4" Long	1
7	914-3814	2-Bolt, 1-1/2" Bearing	1
8	912-0013	2" Nylon Roller Complete	1
8A	912-0013-1	2" Nylon Roller Only	1
8B	912-0013-2	Inner Sleeve	1
9	808-.75-1.25-14	3/4" I.D. x 1-1/4" O.D. x 14Ga. Machine Bushing	4
10	851-7510-3Z	3/4-10 x 3" Machine Bolt Zinc	1
11	910-3755	Reduction Sprocket Weldment-Nonshear	1
12	925-3777-1	Tightener Extension Arm	1
13	14-0031	2" Bearing 4-Bolt	3
14	925-3779-1	3/4-10 x 3" Machine Bolt-Special	1
15	933-3640	Grease Line, Rear 1st Reduction 21"	1
16	808-1.5-2.25-10	12-Machine Bushings (10 - For Split Sprocket) (Prior to serial #SI088720425)	AR
	808-1.75-2.5-10	12-Machine Bushings (10 - For Split Sprocket)(Serial #SI088720426 & Later)	AR
17	910-0089	80B20 1-1/2" Bore Solid Sprocket (Prior to serial #SI088720425)	1
	910-0120	80B20 1-3/4" Bore Solid Sprocket (Serial #SI088720426 & Later)	1
18	925-3601	Front Bearing Plate	1
19	923-3755	PTO Splined Shaft 1-1/2x42-3/4" (Prior to serial #SI078720427)	1
	923-3755-S	PTO Splined Shaft 1-1/2x34-3/4" (Serial #SI078720427-SI088720425)	1
	923-3757	PTO Splined Shaft 1-3/4x34-3/4" (Serial #SI088720426 & Later)	1
20	911-0069	#80-119 Roller Chain	1
21	911-0054	#80-94 Roller Chain 1000 RPM	1
21	911-0068	#80-78 Roller Chain 540 RPM	1
22	933-3631	Grease Line, Front Center Shaft Bearing	1
23	933-3646	Grease Line, Center Bearing Center Shaft, Left Side	1
24	933-3645	Grease Line, Rear Center Shaft Bearing to Right Side	1
25	925-3779	Tightener Arm Assembly	1
26	35-0010	Key, 3/8 x 1-1/2"	1
27	910-0074	80B24 Sprocket 1-1/2" Bore,11 RPM Standard (Prior to Serial #SI088720425)	1
	910-0121	80B24 Sprocket 1-3/4" Bore,11 RPM Standard (Serial #SI088720426 & Later)	1
	910-0069	80B22 Sprocket 1-1/2" Bore,10 RPM (Prior to Serial #SI088720425)	1
	910-0122	80B22 Sprocket 1-3/4" Bore,10 RPM (Serial #SI088720426 & Later)	1
	910-0075	80B18 Sprocket 1-1/2" Bore 8.25 RPM (Prior to Serial #SI088720425)	1
	910-0123	80B18 Sprocket 1-3/4" Bore 8.25 RPM (Serial #SI088720426 & Later)	1
	910-0068	80B16 Sprocket 1-1/2" Bore 7.30 RPM (Prior to Serial #SI088720425)	1
	910-0124	80B16 Sprocket 1-3/4" Bore 7.30 RPM (Serial #SI088720426 & Later)	1
28	808-1.5-2.25-10	9-Machine Bushings (6-For Split Sprocket)(Prior to serial #SI088720425)	AR
	808-1.75-2.5-10	9-Machine Bushings (6-For Split Sprocket)(Serial #SI088720426 & Later)	AR
29	935-0001	Key, 3/8 x 2", Hardened	1
30	901-3751-30	Rear Bearing Vertical Back Plate Welded Assy. (Serial #SI078720427 & Later) (Bolt On Plate Only)	1
31	925-3822-6	2-Chain Link For Tightener	1

SECOND REDUCTION DRIVE

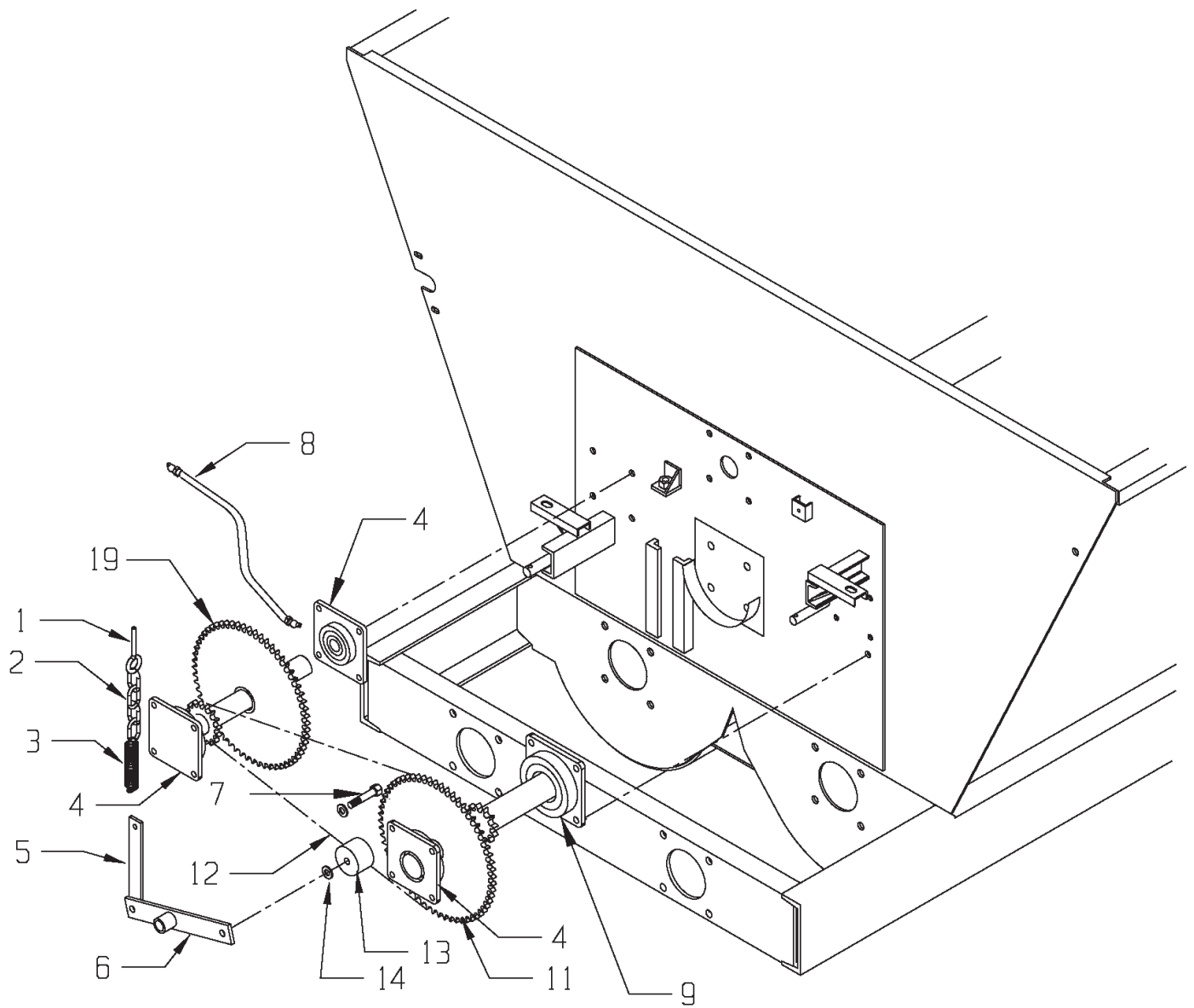

SECOND REDUCTION DRIVE

KEY	PART NO.	DESCRIPTION	QTY
1	933-3804	Eyebolt, 5/16 x 5" / 4" Thread Length	1
2	925-3823-6	4-Chain Link For Tightener	1
3	929-0003	Extension Spring	1
4	14-0031	2" Bearing 4-Bolt	2
5	925-3777-2	Tighener Extension Arm	1
6	925-3779	Tightener Arm	1
7	851-7510-3Z	3/4-10 x 3" Machine Bolt Zinc	1
8	933-3642	Grease Line, 2nd Reduction Rear Bearing, 60"	1
9	914-3811	2-1/2" Bearing, 4-Bolt	1
10	910-3755	Reduction Sprocket Weldment-Nonshear	1
11	910-3753	Industrial 2nd Reduction Wldmt	1
12	911-0053	#80-102 Roller Chain, 2nd Reduction Chain	1
13	912-0013	2" Nylon Roller Complete	1
13A	912-0013-1	2" Nylon Roller Only	1
13B	912-0013-2	Inner Sleeve	1
14	808-.75-1.25-14	3/4" ID x 1-1/4" OD Machine Bushing 14 Ga.	2

THIRD REDUCTION DRIVE

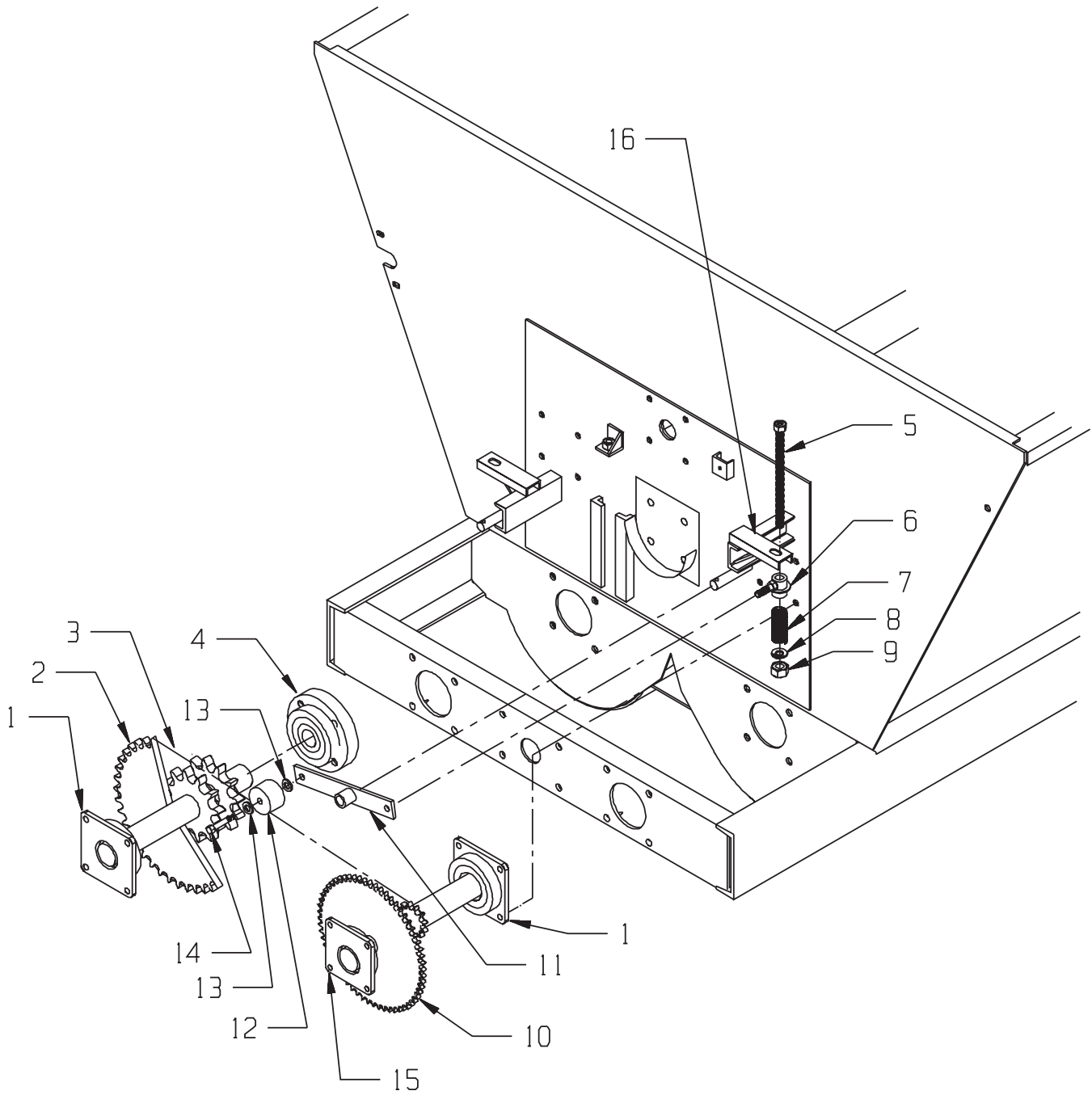

THIRD REDUCTION DRIVE

KEY	PART NO.	DESCRIPTION	QTY
1	914-3811	2 ½" 4-Bolt Bearing	2
2	910-3754-HD	Industrial 3rd Reduction Weldment	1
3	911-0062	#120-47 Roller Chain, 3rd Reduction Chain	1
4	914-3807A	2 ½" Round Bearing	1
5	925-3783	Tightener Bolt Assembly	1
6	925-3782	#120 Chain, Tightener Linkage	1
7	29-0009	Tightener Spring	1
8	925-3807-3	Retaining Washer	1
9	815-7510-Z	3/4-10 Nylon Locknut	2
10	910-3753-HD	Industrial 2nd Reduction	1
11	925-3779	Tightener Arm	1
12	912-0013	2" Nylon Roller Complete	1
12A	912-0013-1	2" Nylon Roller Only	1
12B	912-0013-2	Inner Sleeve	1
13	808-.75-1.25-14	3/4" ID x 1-1/4" OD Machine Bushing 14 Ga.	2
14	851-7510-3Z	3/4-10 x 3" Machine Bolt Zinc	1
15	14-0031	2" Bearing, 4-Bolt	1
16	901-3750-49	#120 Tightener Pivot	1

FINAL REDUCTION, RH AUGER DRIVE

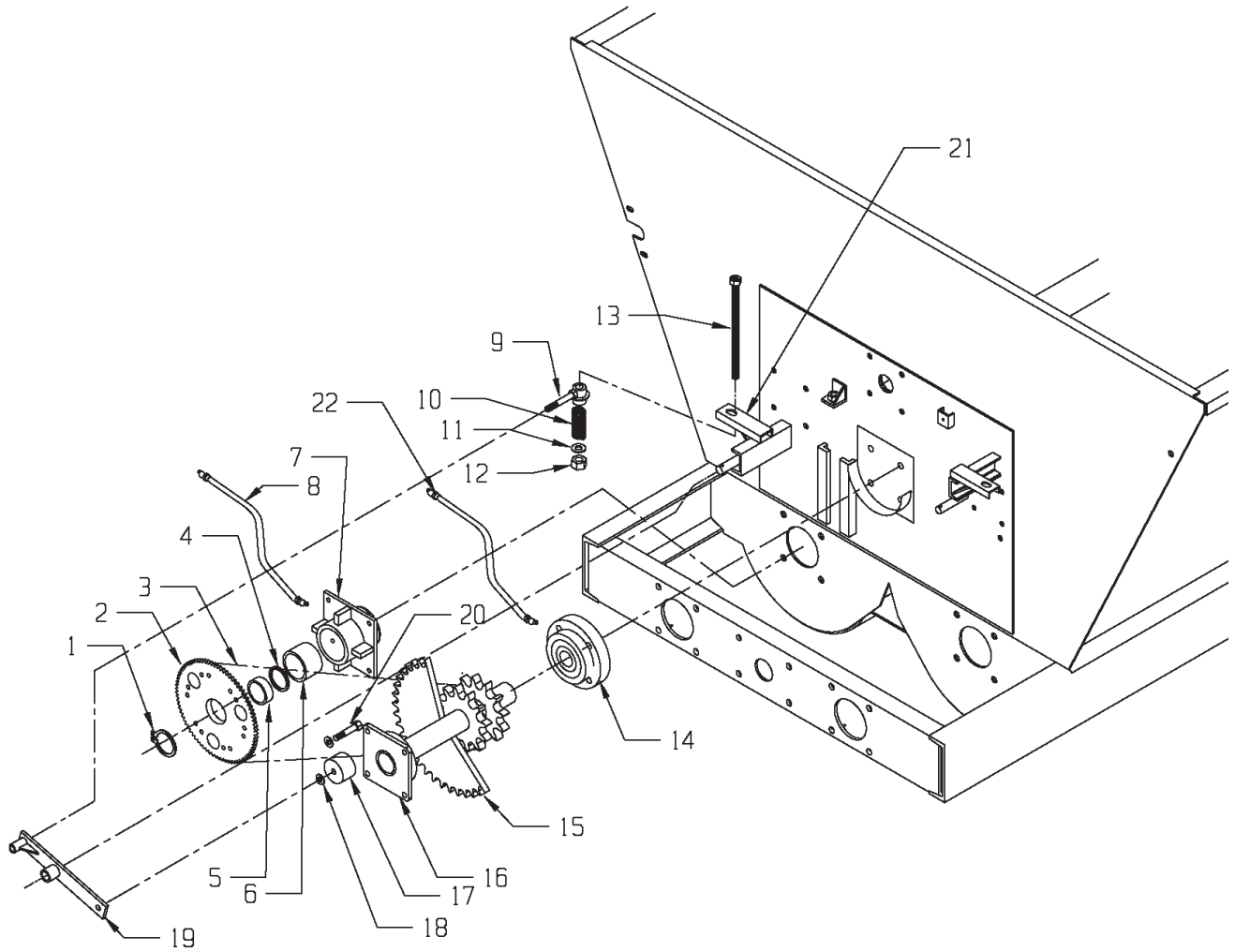

FINAL REDUCTION, RH AUGER DRIVE

KEY	PART NO.	DESCRIPTION	QTY
1	933-3701	3" Retaining Ring	1
2	910-0100	140B35 Shear Sprocket Assembly	1
2A	831-5618-1.75	9/16-18 x 1-3/4" Allen Head Cap Screw Grade 8 (Prior to Serial #SI088720/8865287)	AR
	831-5618-2.25	9/16-18 x 2-1/4" Allen Head Cap Screw Grade 8 (Prior to Serial #SI088720/8865287)	AR
	831-6318-1.75	5/8-18 x 1-3/4" Allen Head Cap Screw Grade 8 (Serial #SI088720/8865287 & Later)	AR
2B	884-5618	9/16-18 Top Locknut Grade 8 (Prior to Serial #SI088720/8865287)	AR
	884-6318	5/8-18 Top Locknut Grade 8 (Serial #SI088720/8865287 & Later)	AR
3	911-0065	140-47 Roller Chain	1
4	933-3704	Front Auger Washer Steel	1
5	933-3750	Auger Sprocket Spacer 1-1/2" Long	1
6	913-3701	Nylon Bushing 3" I.D. x 4" O.D. x 3-3/8" Long	1
7	925-3766	Front Bushing Holder Assembly W/Nylon	1
8	933-3626	Grease Line, Right Auger Bushing Holder	1
9	925-3781	Right Auger Chain Tightener Linkage	1
10	29-0009	Tightener Spring	1
11	925-3807-3	Retaining Washer	1
12	815-7510-Z	3/4-10 Nylon Locknut	1
13	925-3783	Tightener Bolt Assembly	1
14	914-3807A	2-1/2" Round 4-Bolt Bearing	1
15	910-3754-HD	3rd Reduction Weldment	1
16	914-3811	2-1/2" Bearing 4-Bolt	1
17	912-0013	2" Nylon Roller Complete	1
17A	912-0013-1	2" Nylon Roller Only	1
17B	912-0013-2	Inner Sleeve	1
18	808-.75-1.25-14	3/4" I.D. x 1-1/4" O.D. Machine Bushing 14 Ga.	2
19	925-3778	Right Auger Tightener Arm Assembly Less Roller	1
20	925-3778-3	3/4-10 x 2-3/4" Machine Bolt Special	1
21	901-3751-11	#120 Tightener Pivot	1
22	933-3641	Grease Line, 2-1/2" Rear Bearing	1

FINAL REDUCTION, LH AUGER & THIRD AUGER DRIVE

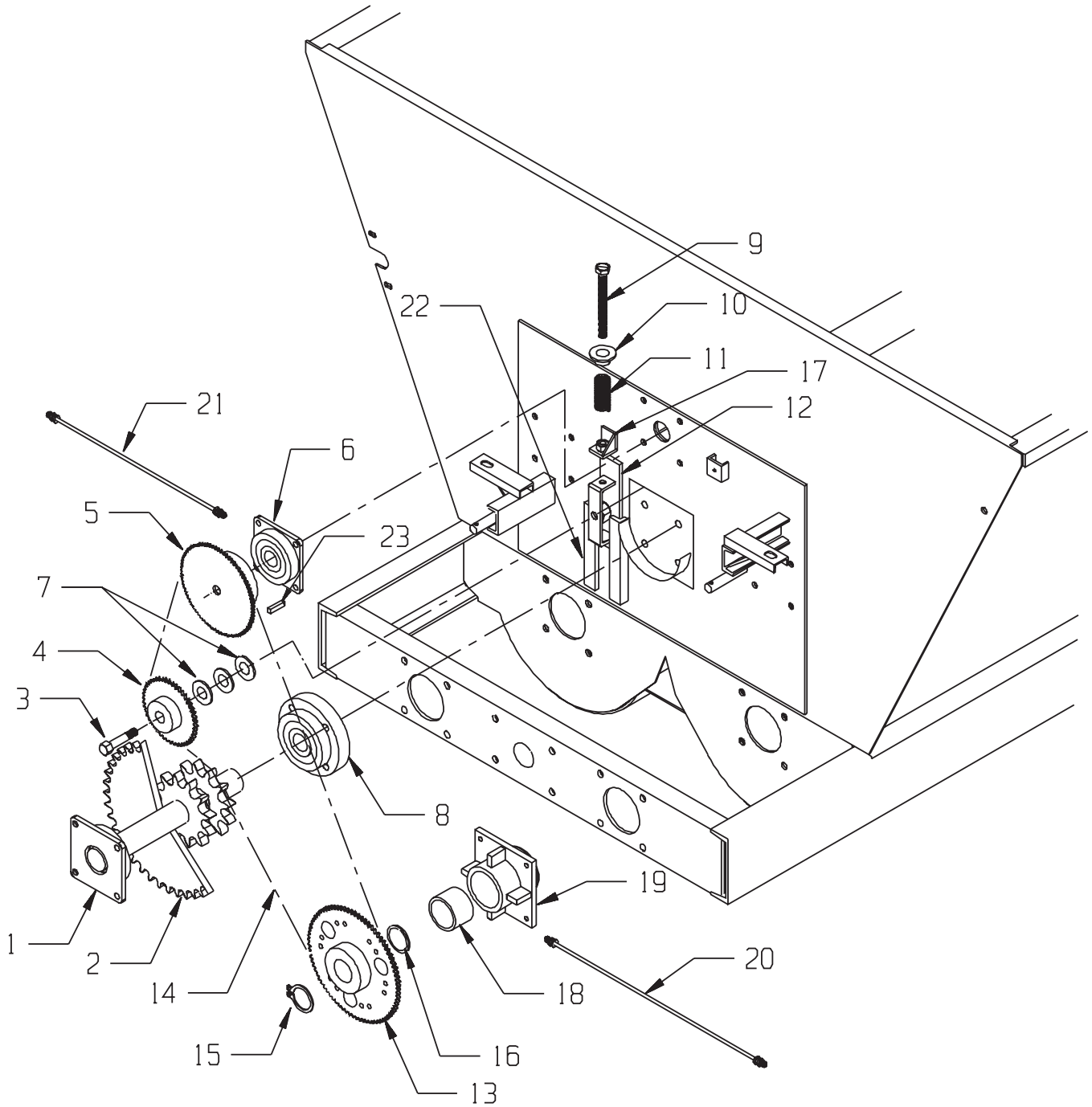

FINAL REDUCTION, LH AUGER & THIRD AUGER DRIVE

KEY	PART NO.	DESCRIPTION	QTY
1	914-3811	2-1/2" Bearing 4-Bolt	1
2	910-3754-HD	8720 3rd Reduction Weldment	1
3	925-3719-4	3/4-10 x 3-1/2" Machine Bolt-Special	1
4	912-0008	140C12 Idler Sprocket	1
4A	910-0006-1	Idler Bearing	2
5	910-0087	140B28 2-1/2" Bore Sprocket	1
6	914-3811	2-1/2" Bearing 4-Bolt	1
7	805-0075-Z	3/4" Flat Washer	AR
8	914-3807A	2-1/2" Round Bearing	1
9	925-3732	Tightener Bolt Welded Assembly	1
10	925-3841	Outer Spring Tightener Guide	1
11	29-0009	Compression Spring	1
12	925-3719	#140 Chain Tightener Bracket Assembly	1
13	910-0100	140B35 Shear Sprocket Assembly	1
13A	831-5618-1.75	9/16-18 x 1-3/4" Allen Head Cap Screw Grade 8 (Prior to Serial #SI088720/8865287)	AR
	831-5618-2.25	9/16-18 x 2-1/4" Allen Head Cap Screw Grade 8 (Prior to Serial #SI088720/8865287)	AR
	831-6318-1.75	5/8-18 x 1-3/4" Allen Head Cap Screw Grade 8 (Serial #SI088720/8865287 & Later)	AR
13B	884-5618	9/16-18 Top Locknut Grade 8 (Prior to Serial #SI088720/8865287)	AR
	884-6318	5/8-18 Top Locknut Grade 8 (Serial #SI088720/8865287 & Later)	AR
14	911-0067	#140-80 Roller Chain, Left Auger Chain	1
15	933-3701	3" Retaining Ring	1
16	933-3704	Front Auger Washer Steel	1
17	925-3731	#140 Tightener Angle Welded Assembly	1
18	913-3701	Nylon Bushing 3" ID x 4" OD x 3-3/8" Long	1
19	925-3766	Front Bushing Holder Assembly W/Bushing	1
20	933-3644	Grease Line, Left Auger Bushing Holder	1
21	933-3641	Grease Line, 2-1/2" 3rd Auger Bearing	1
22	901-3701-36	Tightener Slide Welded Assembly	2
23	35-0024	1/2 x 1/2 x 2-1/2" Square Key	1

BODY, SHIELDS & AUGERS - 8720 SPREADER

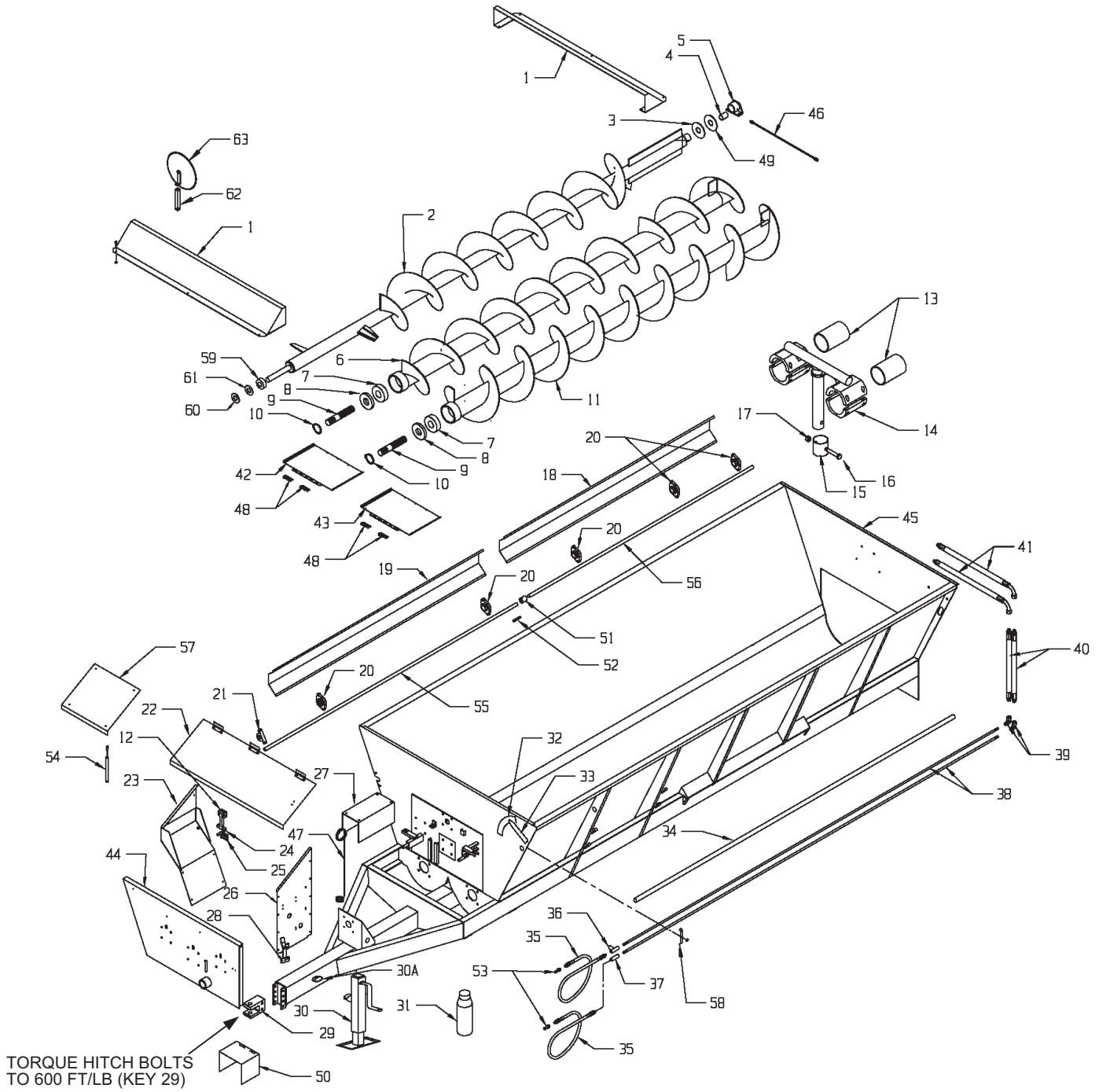

BODY, SHIELDS & AUGERS - 8720 SPREADER

KEY	PART NO.	DESCRIPTION	QTY				
1	901-3765	Splash Guard Assy. 45°	2	27	924-3758-1	Center Shaft Shield	1
	901-3769	Splash Guard Assy. 75°	2	28	925-3775-1	PTO Holder Bracket	1
2	926-3764	3rd Auger Assy.	1	29	901-3759-2	Bolt On Swivel Hitch Assembly	1
3	933-3703	Bronze Washer	1	29A	901-3755-4	1-14x6-1/2" Grade 8 Machine Bolt	4
4	913-3701	Nylon Bushing	1	29B	884-1014-Z	1-14 Top Locknut Gr 8	4
5	925-3770	3rd Auger Bushing Holder W/Nylon	1	30	956-3702-1	Jack	1
6	926-3763	Right Auger Assy.	1	30A	956-3702-2	Jack Mount Tube	1
	926-3701-2	Front Splined Sleeve	1	30B	956-3702-1-1	Pin & Chain Assy.	1
	926-3701-2-1	Rear Splined Sleeve W/Cap Washer	1	30C	956-3702-1-3	Screw Nut/Bearing Washer Kit	1
	926-3750-3	Front Seal Collar	1	30D	956-3702-1-2	Gear Bushing Pin Re- pair Kit	1
	926-3770-2	Flighting Gusset	2	31	33-0044	Manual Holder W/Cap	1
	926-3771-1	3/8" Right Hand Sec- tional Flighting	AR	32	46-7000-1	Gate Indicator Decal	1
	926-3771-2	Right Auger Knife	1	33	925-3762	Gate Indicator Assem- bly	1
7	914-3812- NSM	Front Auger Thrust Bearing, NSM Nylatron	2	34	925-8720-1	Indicator Pipe	1
8	914-3813	Front Auger Thrust Bearing Seal	2	35	955-3701	3/8 x 132" Hyd. Hose	2
9	926-3701-1	Splined Auger Shaft 23 Tooth 3" Diameter	2	36	955-3803	3/8" Black Pipe Tee	1
10	933-3701	3" Retaining Ring	2	37	955-3609	3/8" Black Coupler	1
11	926-3762	Left Auger Assy.		38	955-3760	3/8 x 198" Hyd. Pipe	2
	926-3701-2	Front Splined Sleeve	1	39	955-3605	3/8 x 90° Black Elbow	2
	926-3701-2-1	Rear Splined Sleeve W/Cap Washer	1	40	955-3756	3/8 x 24" Hyd. Pipe	2
	926-3750-3	Front Seal Collar	1	41	955-3825	3/8 x 56" Hyd. Hose	2
	926-3770-2	Flighting Gusset	2	42	924-3762	R. Lower Auger Sprocket Shield Assy.	1
	926-3770-1	3/8" Left Hand Sec- tional Flighting	AR	43	924-3763	L. Lower Auger Sprocket Shield Assy.	1
	926-3770-5	Left Auger Knife	1	44	925-3750	Front Outer Plate Assy.	1
12	32-0027-1	Upper T-Latch Bracket	1		925-3750-TR	Front Outer Plate Assy. Truck Mount	1
13	925-3771-9	Nylon Bearing (2-Per Auger)	4	45	901-8720	Main Body	1
14	925-3773	Auger Holdown Assy. W/Nylon	1	46	933-3632	Grease Line 3rd Auger Rear Bearing 36"	1
15	925-3771-4	T-Post Holdown Bot- tom Collar	1	47	929-3801	Hydraulic Hose Holder Spring	1
16	881-1008-5Z	1-08 x 5" Grade 8 Ma- chine Bolt	1	48	823-.25-5Z	1/4 x 5" Hair Pin	4
17	884-1008	1-08 Grade 8 Top Locknut	1	49	933-3704	Steel Washer	1
18	924-3755	Rear Side Shield	1	50	931-3810	PTO Guard Assy.	1
19	924-3766	Front Side Shield	1	51	937-0004	1-1/2" Shaft Coupler	1
20	914-3814	2-Bolt 1-1/2" Bearing	5	52	35-0022	3/8 x 3/8 x 4-1/2" Key	1
21	914-3804	1-1/2" Pillow Block Bearing	1	53	55-0013	Male Pioneer Tip	2
22	924-3753	Front Cover Assembly	1	54	955-3703	Gas Lift Assist Spring	1
23	924-3756	Right Front Shield As- sembly	1	55	923-3756	Front Side Shaft	1
24	32-0027-2	Rubber T-Latch	1	56	923-3704	Rear Side Shaft	1
25	32-0027-3	Lower T-Latch Bracket	1	57	924-3752	Right Hand Front Cover	1
26	924-3757	Left Front Support Plate	1	58	933-3602	Hydraulic Pipe Bracket	5
				59	933-3753	Shaft Collar 2-1/2"	1
				60	933-3801	Bronze Washer 2-1/2"	1
				61	933-3802	Steel Washer 2-5/8"	1
				62	925-3774	Mirror Bracket	1
				63	56-0029	Mirror	1

BODY, SHIELDS & AUGERS - 8865 SPREADER

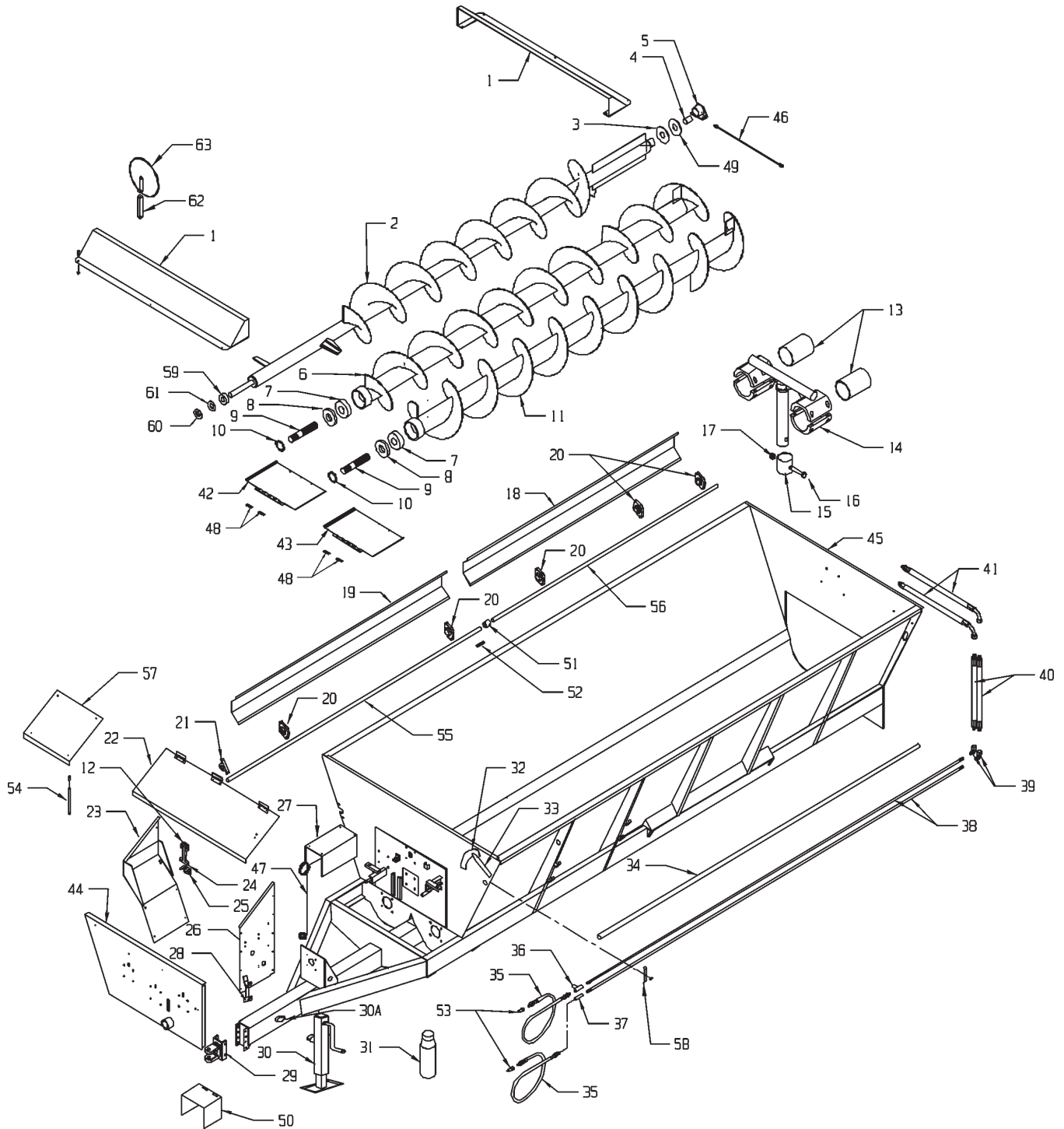

BODY, SHIELDS & AUGERS - 8865 SPREADER

KEY	PART NO.	DESCRIPTION	QTY
1	901-3765	Splash Guard Assy. 45 Degree	2
2	926-3760	3rd Auger Assy.	1
3	933-3703	Bronze Washer	1
4	913-3701	Nylon Bushing	1
5	925-3770	3rd Auger Bushing Holder W/Nylon	1
6	926-3770	Right Auger Assy.	1
	926-3701-2	Front Splined Sleeve	1
	926-3701-2-1	Rear Splined Sleeve W/Cap Washer	1
	926-3750-3	Front Seal Collar	1
	926-3770-2	Flighting Gusset	2
	926-3771-1	3/8" Right Hand Sec- tional Flighting	AR
	926-3771-2	Right Auger Knife	1
7	914-3812- NSM	Front Auger Thrust Bearing	2
8	914-3813	Front Auger Thrust Bearing Seal	2
9	926-3701-1	Splined Auger Shaft 23 Tooth 3" Diameter	2
10	933-3701	3" Retaining Ring	2
11	926-3771	Left Auger Assy.	1
	926-3701-2	Front Splined Sleeve	1
	926-3701-2-1	Rear Splined Sleeve W/Cap Washer	1
	926-3750-3	Front Seal Collar	1
	926-3770-2	Flighting Gusset	2
	926-3770-1	3/8" Leftt Hand Sec- tional Flighting	AR
926-3770-5	Left Auger Knife	1	
12	32-0027-1	Upper T-Latch Bracket	1
13	925-3771-9	Nylon Bearing (2-Per Auger)	4
14	925-3773	Auger Holdown Assy. W/Nylon	1
15	925-3771-4	T-Post Holdown Bot- tom Collar	1
16	881-1008-5Z	1-08 x 5" Grade 8 Ma- chine Bolt	1
17	884-1008	1-08 Grade 8 Top Locknut	1
18	924-3755	Rear Side Shield	1
19	924-3754	Front Side Shield	1
20	914-3814	2-Bolt 1-1/2" Bearing	5
21	914-3804	1-1/2" Pillow Block Bearing	1
22	924-3753	Front Cover Assembly	1
23	924-3756	Right Front Shield As- sembly	1
24	32-0027-2	Rubber T-Latch	1
25	32-0027-3	Lower T-Latch Bracket	1
26	924-3757	8865 Left Front Sup- port Plate	1
27	924-3758-1	Center Shaft Shield	1
28	925-3775-1	PTO Holder Bracket	1
29	901-3757	Bolt On Swivel Hitch Assembly	1
29A	881-1014-2.5Z	1-14x2-1/2" Grade 8 Machine Bolt	4

KEY	PART NO.	DESCRIPTION	QTY
29B	884-1014-Z	1-14 Top Locknut Grade 8	4
30	956-3702-1	Jack	1
30A	956-3702-2	Jack Mount Tube	1
30B	956-3702-1-1	Pin & Chain Assy.	1
30C	956-3702-1-3	Screw Nut/Bearing Washer Kit	1
30D	956-3702-1-2	Gear Bushing Pin Re- pair Kit	1
31	33-0044	Manual Holder W/Cap	1
32	46-7000-1	Gate Indicator Decal	1
33	925-3762	Gate Indicator Assem- bly	1
34	925-3765	Indicator Pipe	1
35	955-3701	3/8 x 132" Hyd. Hose	2
36	955-3803	3/8" Black Pipe Tee	1
37	955-3609	3/8" Black Coupler	1
38	955-3755	3/8 x 238" Hyd. Pipe	2
39	955-3605	3/8 x 90* Black Elbow	2
40	955-3756	3/8 x 24" Hyd. Pipe	2
41	955-3825	3/8 x 56" Hyd. Hose	2
42	924-3762	R. Lower Auger Sprocket Shield Assy.	1
43	924-3763	L. Lower Auger Sprocket Shield Assy.	1
44	925-3750	Front Outer Plate Assy.	1
	925-3750-TR	Front Outer Plate Assy. Truck Mount	1
45	901-3751	Main Body	1
46	933-3647	Grease Line 3rd Auger Rear Bearing	1
47	929-3801	Hydraulic Hose Holder Spring	1
48	823-.25-5Z	1/4x5" Hair Pin	4
49	933-3704	Steel Washer	1
50	931-3810	PTO Guard Assy.	1
51	937-0004	1-1/2" Shaft Coupler	1
52	35-0022	3/8 x 3/8 x 4-1/2" Key	1
53	55-0013	Male Pioneer Tip	2
54	955-3703	Gas Lift Assist Spring	1
55	923-3754	Front Side Shaft	1
56	923-3704	Rear Side Shaft	1
57	924-3752	Right Hand Front Cover	1
58	933-3602	Hydraulic Pipe Bracket	5
59	933-3753	Shaft Collar 2-1/2"	1
60	933-3801	Bronze Washer 2-1/2"	1
61	933-3802	Steel Washer 2-5/8"	1
62	925-3774	Mirror Bracket	1
63	56-0029	Mirror	1

REAR GATE & SHIELDS

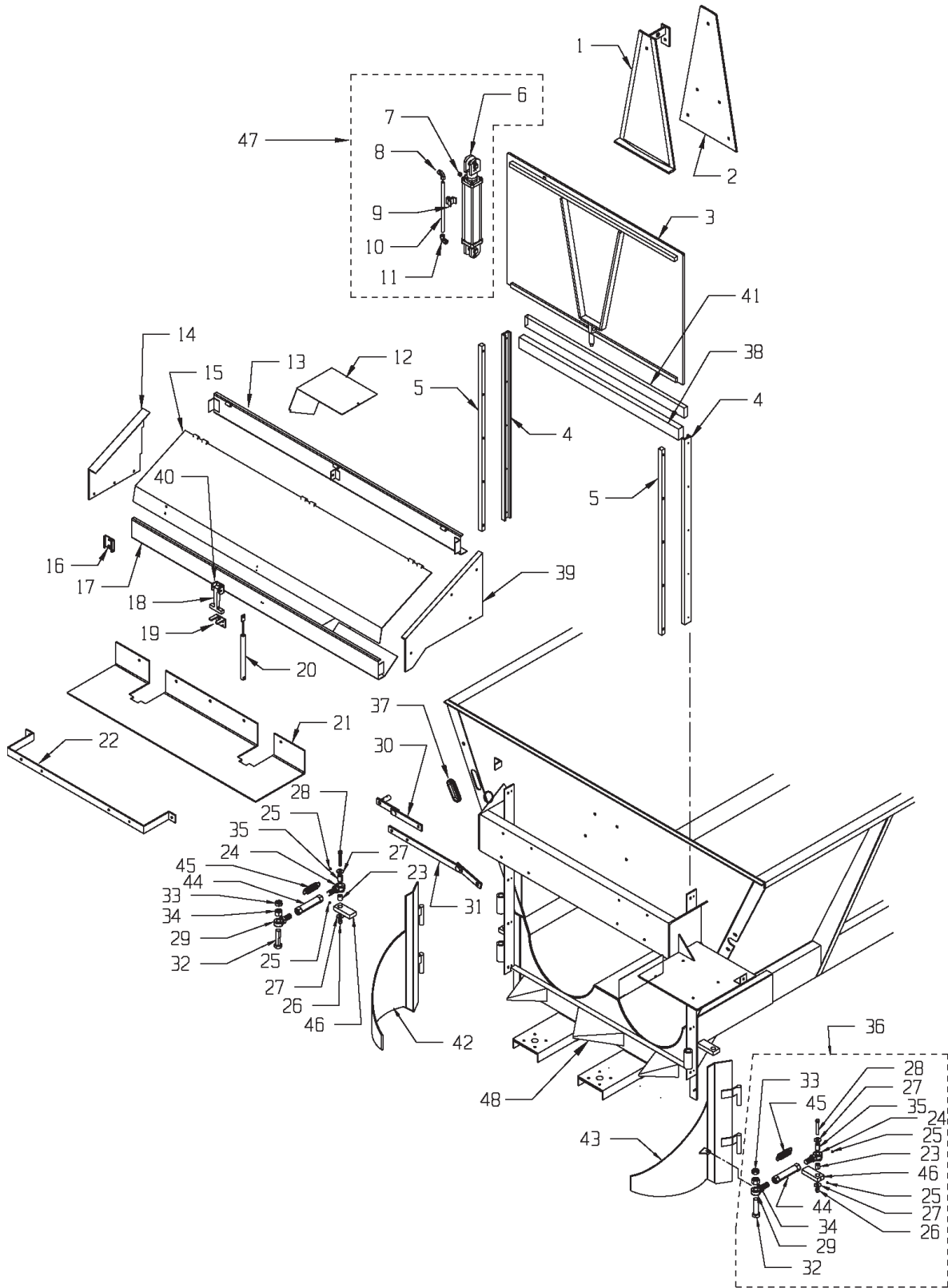

REAR GATE & SHIELDS

KEY	PART NO.	DESCRIPTION	QTY
1	925-3759	Back Cylinder Plate Weldment	1
2	925-3758-1	Front Cylinder Plate	1
3	901-3766	Rear Gate Assembly W/Peg	1
4	949-3750	Poly Gate Slides	2
5	901-3764-1	Rear Gate Guide	2
6	955-0011	Hydraulic Cylinder Center Lift	1
7	955-3802-2	½ x 3/8" Steel Hex Bushing	1
8	955-3605	3/8 x 90 Degree Elbow	1
9	925-3754	Hydraulic Pipe Holder Weldment	1
10	955-3753	3/8 x 32" Hydraulic Pipe	1
11	55-0092	Street Elbow ½" M x 3/8" Female	1
12	924-3761	Right Rear Upper Shield	1
13	924-3750-2	Rear Shield Upper Mount Plate Assy.	1
14	924-3751	Rear Shield Left Cap	1
15	924-3750	Rear Main Cover Assy.	1
16	33-1002	Slow Moving Vehicle Bracket	1
17	924-3760	Rear Shield Lower Mount Plate Assy.	1
18	32-0027-2	Rubber T-Latch	1
19	32-0027-3	Lower T-Latch Bracket	1
20	955-3703	Gas Lift Assist Spring	1
21	925-3760-1	Gearbox Rear Plate	1
22	925-3761-1	Gearbox Mount Strap	1
23	925-13804-1	1" Shear Sleeve	2
24	925-13902	RH Tie Rod Eye Welded Assy. W/Jam Nut	2
25	827-2528-38	Set Screw, 1/4-28 x 3/8"	4
26	815-5013-Z	Nylon Locknut, ½-13	6
27	805-0050-Z	Flat Washer, ½	12
28	851-5013-3.5Z	Machine Bolt, ½ x 3-1/2" Grade 5	2
29	75-0304	LH Tie Rod Eye W/Jam Nut	2
30	925-3767	Indicator Linkage Assy.	1

KEY	PART NO.	DESCRIPTION	QTY
31	925-3763	Gate Indicator Linkage	1
32	75-0413-1A	Machine Bolt, Gr 5, 1-14 x 4"	2
33	75-0305-2	Jam Nut, 1-14, RH	2
34	884-1014-Z	Top Locknut, 1-14	2
35	925-13903	1-3/8" Shear Sleeve	2
36	925-13803-KIT	Linkage Arm Kit	AR
37	33-1009	Plastic Trim (By the Foot)	AR
38	949-3751	Top Poly Gate Seal	1
39	924-3759	Rear Shield Right Cap	1
40	32-0027-1	Upper T Latch Bracket	1
41	949-3752	Poly Gate Seal Spacer	1
42	925-13802	L. Cupped Material Guide	1
43	925-13801	R. Cupped Material Guide	1
44	925-13803	Material Guide Linkage Arm	2
45	929-0003	Extension Spring	2
46	925-3768-1-3-DT	Frame Pivot Block	2
47	955-0011-A SSS	Cylinder w/Brk & Pipe	1
48	901-3751-40	Rear Spinner Deflector Weld on Replacement	1

SPINNERS & GEARBOXES

PADDLE OPTIONS

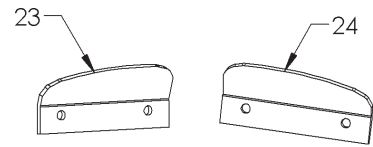

FOR POULTRY OR SLUDGE MANURE.
FOR LOWER TIER OF SPINNER ONLY.

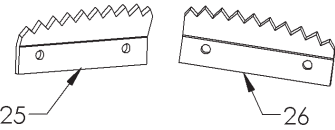

FOR SLUDGE/PASTE MATERIAL WITH
FIBER. LOWER TWO TIERS OF SPINNER.



FOR STANDARD PEN-PACKED MATERIAL
FOR ALL TIERS OF SPINNER.

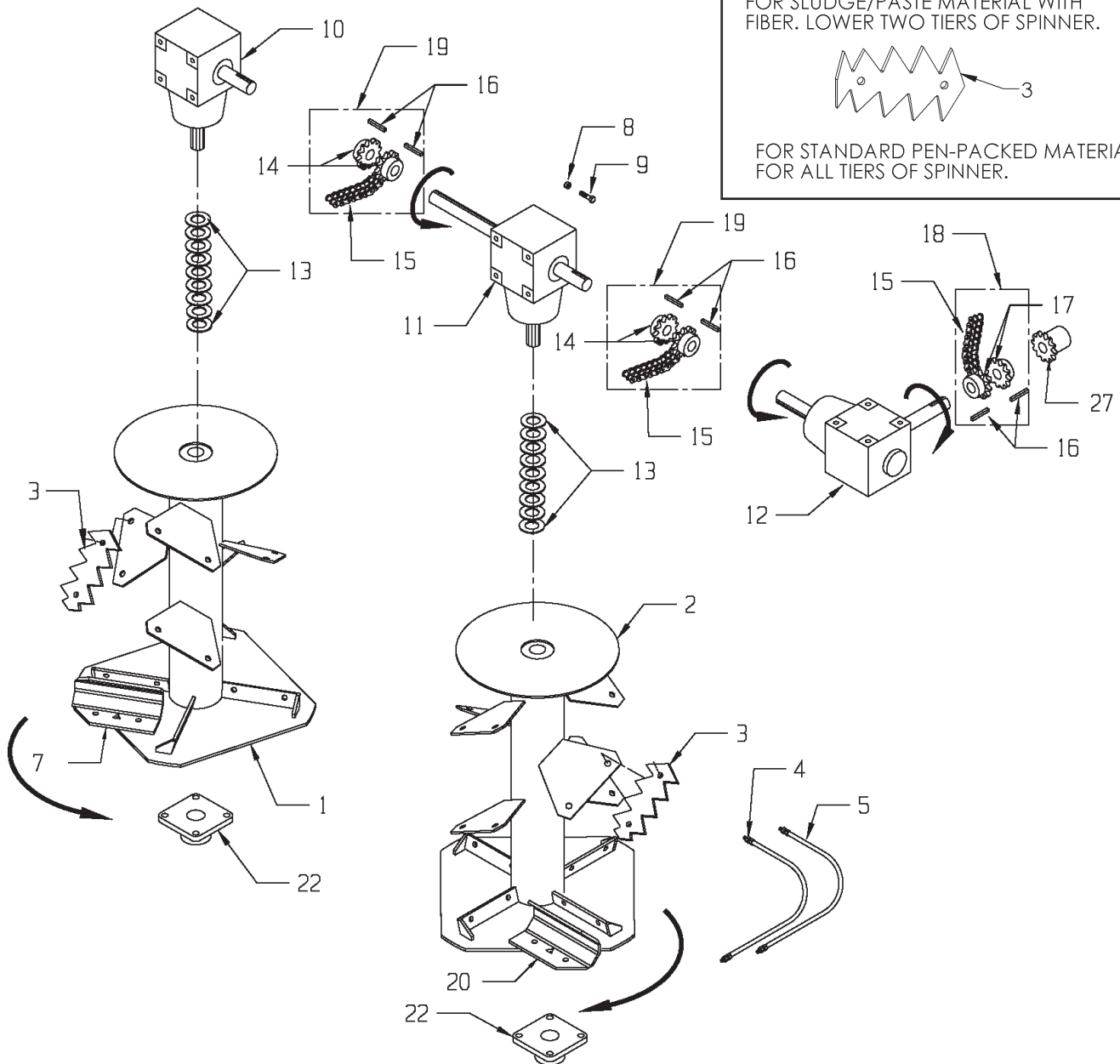

SPINNERS & GEARBOXES

KEY	PART NO.	DESCRIPTION	QTY
1	901-13802	Left Spinner Assembly	1
2	901-13801	Right Spinner Assembly	1
3	901-3753-10	Paddle Tip	AR
4	933-3632	Grease Line, Left Spinner Bearing	1
5	933-3639	Grease Line, Right Spinner Bearing	1
7	901-3753-16	L. Spinner Sand Paddle	4
8	815-3824-Z	3/8-24 Nylon Insert Locknut	4
9	851-3824-1.5Z	3/8-24 x 1-1/2" Fine Thread GR 5 Bolt	4
10	19-0129	Left Spinner Gearbox	1
11	19-0130	Right Spinner Gearbox	1
12	19-0036	Corner Gearbox 1000 RPM Standard	1
	19-0035	Optional 540 Corner Gearbox	1
13	808-1.75-2.5-14	1 3/4 x 2 1/2 x 14 GA M.B. (Prior to SI078720/8865395)	AR
14	937-0010-1	1 3/4" Bore Chain Coupler	2
15	937-0009-2	Coupler Chain	2
16	935-0001	3/8 x 3/8 x 2" Key, Hardened	8
17	937-0009-1	1 1/2" Bore Chain Coupler	2
18	937-0009	1 1/2" Chain Coupler Kit (Prior to 08 SN's)	1
19	937-0010	1 3/4" Chain Coupler Kit	1
20	901-3753-15	R. Spinner Sand Paddle	4
22	914-3815	2" - 4 Bolt Bearing	2
23	901-3754-2	LH Poultry/Sludge Paddle	2
24	901-3753-13	RH Poultry/Sludge Paddle	2
25	901-3753-19	LH Sludge/Paste Paddle	2
26	901-3753-20	RH Sludge/Paste Paddle	2
27	937-0020	Over Running Clutch (08 Models and Later)	1

SPINNER GEAR REDUCER - LEFT HAND (1:1) #19-0129

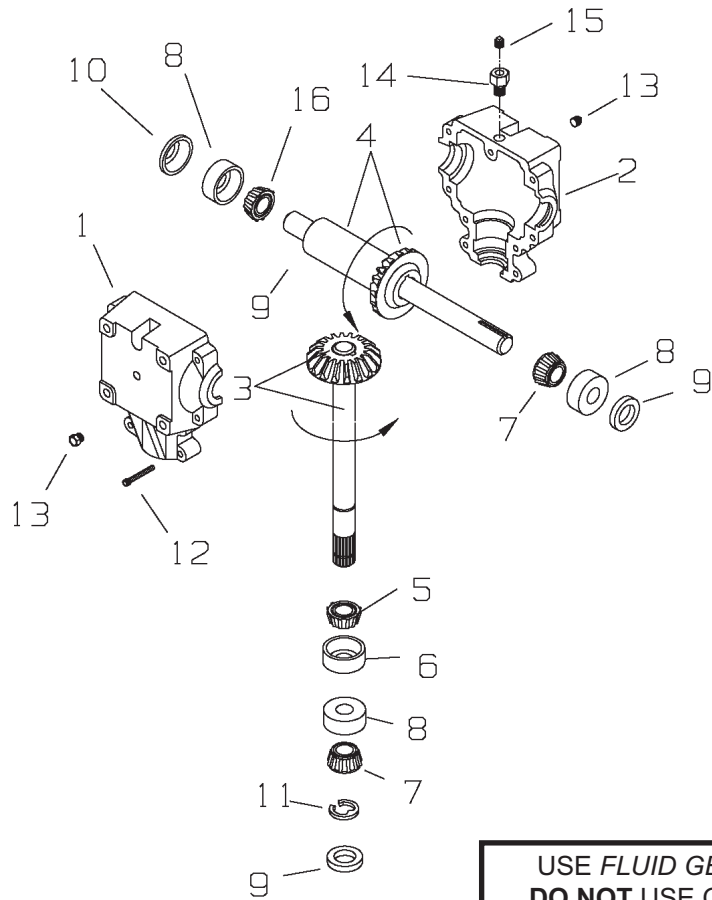

**USE FLUID GEAR GREASE ONLY.
DO NOT USE OIL FOR LUBRICANT.**

KEY	PART NO.	DESCRIPTION
1	19-0029-2	Casting, Machined (Thru Holes)
2	19-0029-1	Casting, Machined (Tapped Holes)
3	19-0029-3	Assy, Pinion Shaft/Gear
4	19-0129-1	Assy, Cross Shaft/Gear
5	19-0029-5	Bearing Cone
6	19-0029-6	Bearing Cup
7	19-0029-7	Bearing Cone
8	19-0029-8	Bearing Cup
9	19-0029-9	Seal 1-3/4"
10	19-0029-10	End Plug, Rubber Cover
11	19-0029-11	Retaining Ring, 1.750
12	19-0016-11	Bolt, 3/8-16 x 2.250 SHCS
13	19-0016-5	Plug, 1/2 NPT
14	19-0029-14	Bushing, 1/4 NPT to 1/8 NPT
15	55-0107	Plug, Breather
16	19-0029-16	Bearing Cone

SPINNER GEAR REDUCER - CENTER (1:1) #19-0130

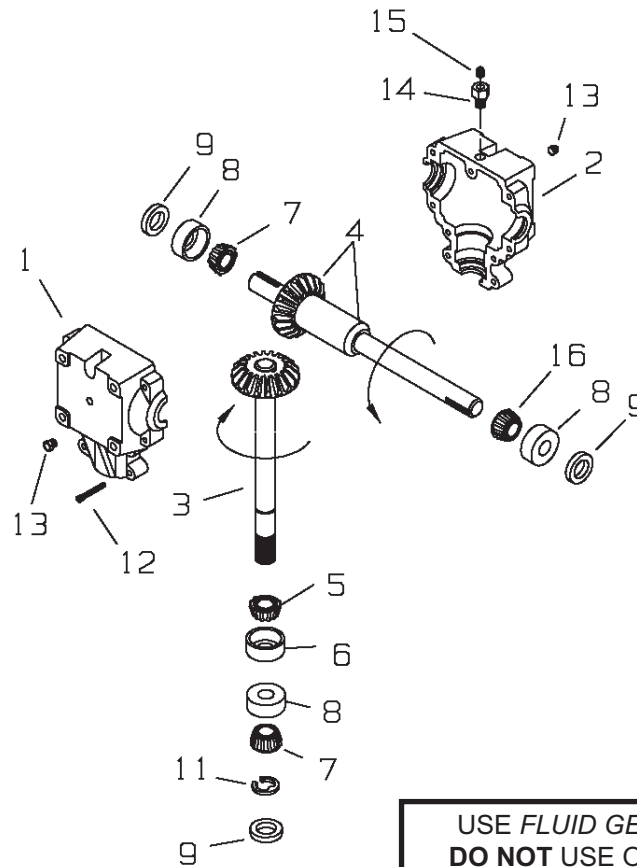

**USE FLUID GEAR GREASE ONLY.
DO NOT USE OIL FOR LUBRICANT.**

KEY	PART NO.	DESCRIPTION
1	19-0029-2	Casting, Machined (Thru Holes)
2	19-0029-1	Casting, Machined (Tapped Holes)
3	19-0029-3	Assy, Pinion Shaft/Gear
4	19-0130-1	Assy, Cross Shaft/Gear
5	19-0029-5	Bearing Cone
6	19-0029-6	Bearing Cup
7	19-0029-7	Bearing Cone
8	19-0029-8	Bearing Cup
9	19-0029-9	Seal 1-3/4"
10	19-0029-10	End Plug, Rubber Cover
11	19-0029-11	Retaining Ring, 1.750
12	19-0016-11	Bolt, 3/8-16 x 2.250 SHCS
13	19-0016-5	Plug, 1/2 NPT
14	19-0029-14	Bushing, 1/4 NPT to 1/8 NPT
15	55-0107	Plug, Breather
16	19-0029-16	Bearing Cone

CORNER GEAR REDUCER - RIGHT HAND

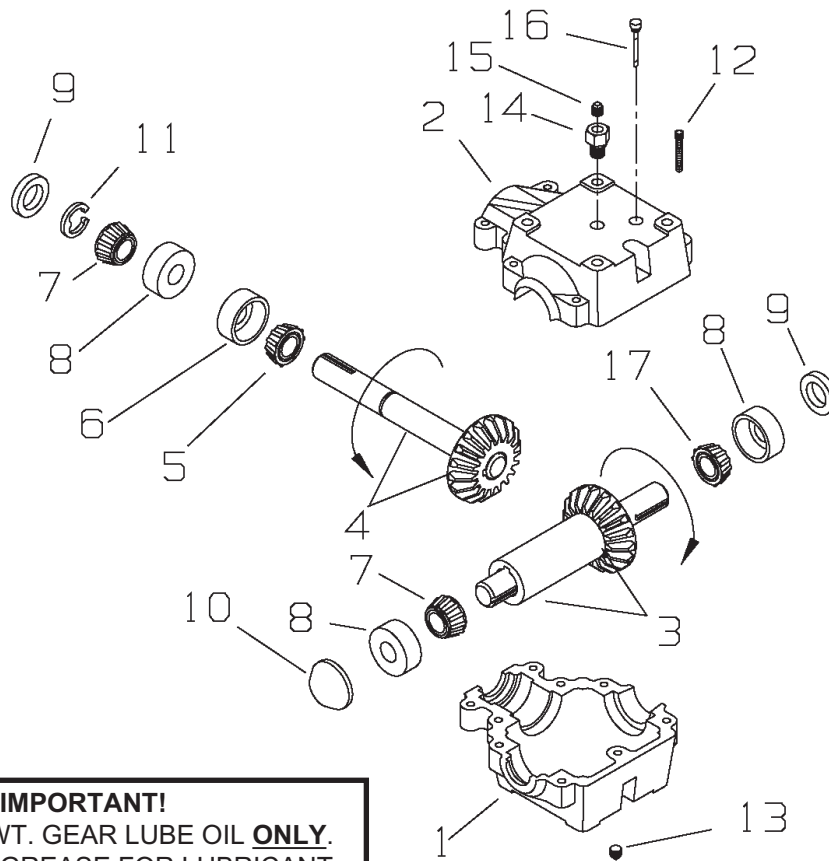

IMPORTANT!
 USE #80-90 WT. GEAR LUBE OIL **ONLY**.
DO NOT USE GREASE FOR LUBRICANT.

KEY	1000 RPM DRIVE PART NO.	540 RPM DRIVE PART NO.	DESCRIPTION
	19-0036	19-0035	Complete Gearbox
1	19-0031-1	19-0031-1	Casting, Machined (Tapped Holes)
2	19-0031-2	19-0031-2	Casting, Machined (Thru Holes)
3	19-0036-1	19-0035-1	Assy, Cross Shaft/Gear
4	19-0031-4	19-0035-2	Assy, Pinion Shaft/Gear
5	19-0029-5	19-0029-5	Bearing Cone
6	19-0029-6	19-0029-6	Bearing Cup
7	19-0029-7	19-0029-7	Bearing Cone
8	19-0029-8	19-0029-8	Bearing Cup
9	19-0029-9	19-0029-9	Seal 1-3/4"
10	19-0029-10	19-0029-10	End Plug, Rubber Cover
11	19-0029-11	19-0029-11	Retaining Ring, 1.750
12	19-0016-11	19-0016-11	Bolt, 3/8-16 x 2.250 SHCS
13	19-0016-5	19-0016-5	Plug, 1/2 NPT
14	19-0023-2	19-0023-2	Bushing, 1/2 NPT to 1/8 NPT
15	19-0002-17	19-0002-17	Plug, Pressure Relief, 5 PSI
16	19-0031-5	19-0031-5	Dip Stick
17	19-0029-16	19-0029-16	Bearing Cone

AXLE & WHEELS (STANDARD 8720)

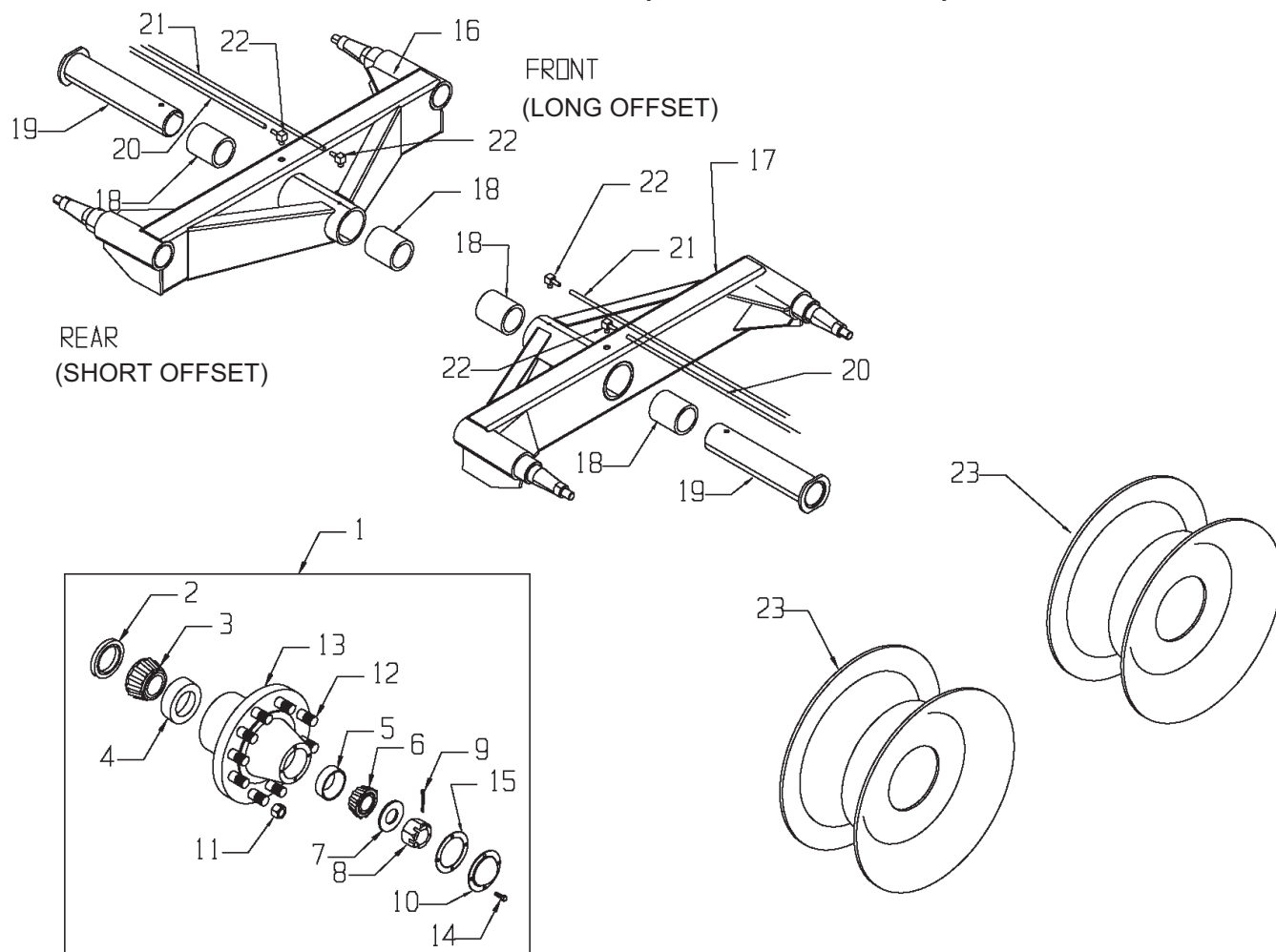

KEY	PART NO.	DESCRIPTION	QTY
1	75-0211	Hub Assembly Complete 15,000#	4
2	75-0211-2	Seal	1
3	75-0211-3	Bearing Cone	1
4	75-0211-4	Bearing Cup	1
5	75-0208-5	Bearing Cup	1
6	75-0208-6	Bearing Cone	1
7	75-0208-7	Washer	1
8	75-0208-8	Nut	1
9	75-0208-9	Cotter Pin	1
10	75-0208-10	Hub Cap	1
11	75-0208-11	Lug Nut - Flanged	10
12	75-0208-12	Stud Bolt	10
13	75-0211-1	Hub Only w/Races & Studs	1
14	75-0208-13	Hub Cap Bolt	4
15	75-0208-14	Hub Cap Gasket	1
16	901-8720-11-1	LH Tandem Wing Assembly, Less Hubs	1

KEY	PART NO.	DESCRIPTION	QTY
17	901-8720-10-1	RH Tandem Wing Assembly, Less Hubs	1
18	901-8720-10-1-4	Nylon Pivot Sleeve	4
19	901-8720-15	O-Beam Pivot Assembly	2
20	955-3761	3/16x10" Grease Hose	2
21	955-3762	3/16X16" Grease Hose	2
22	30-0020	1/8" NPT Street L	4
23	75-0276	10x20 Lock Ring Rim 1600R20 Used Military Tire	4
	75-0273	22.5x13 Wheel 0" Offset 425 Used Truck Tire	4
	75-0270	18X16.1 Wheel 21.5L Implement Tire	4

AXLE & WHEELS, HI-FLOAT PACKAGE (STANDARD 8865) (OPTIONAL 8720)

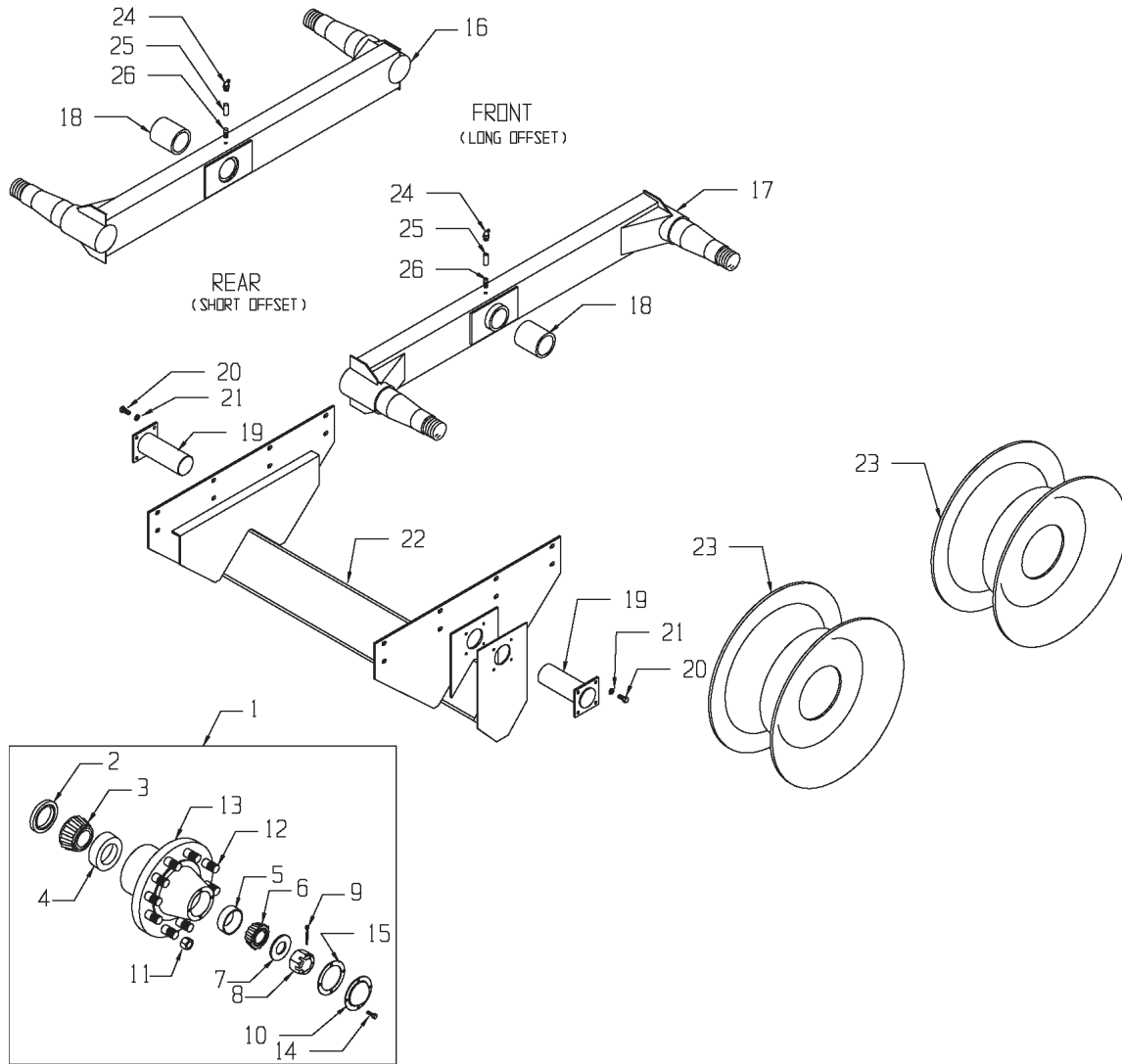

KEY	PART NO.	DESCRIPTION	QTY
1	75-0213	Hub Assembly Complete 20,000#	4
2	75-0213-2	Seal	1
3	75-0213-5	Bearing Cone	1
4	75-0213-10	Bearing Cup	1
5	75-0213-3	Bearing Cup	1
6	75-0213-6	Bearing Cone	1
7	75-0213-12	Washer	1
8	75-0213-13	Nut	1
9	75-0213-14	Cotter Pin	1
10	75-0213-7	Hub Cap	1
11	75-0213-9	Lug Nut - Flanged	10
12	75-0213-4	Stud Bolt	10
13	75-0213-1	Hub Only w/Races & Studs	1
14	75-0213-8	Hub Cap Bolt	4
15	75-0213-11	Hub Cap Gasket	1

KEY	PART NO.	DESCRIPTION	QTY
16	901-3771	LH Tandem Wing Assembly, Less Hubs	1
17	901-3770	RH Tandem Wing Assembly, Less Hubs	1
18	901-3864-2	Nylon Pivot Sleeve	2
19	901-3773	O-Beam Pivot Assembly	2
20	881-6311-1.5Z	5/8-11 x 1 1/2" GR 8 M.B.	8
21	822-0063-Z	5/8" Split Lockwasher	8
22	901-3772	Axle Weldment	1
23	75-0271	DW25-26 Wheel	4
24	30-0006	Zerk 1/8" NPT x 90 Degrees	1
25	30-0009	1/8" NPT Coupler	1
26	30-0008	1/8" NPT Nipple	1

LIGHTS

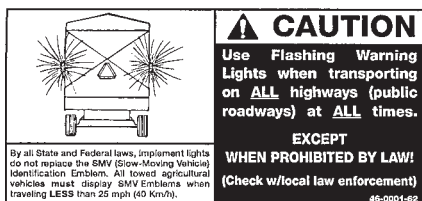

14

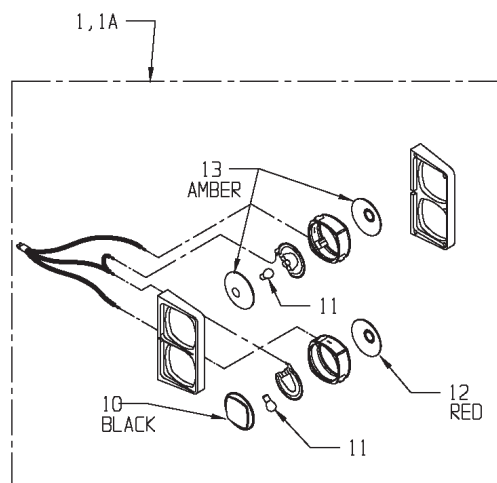
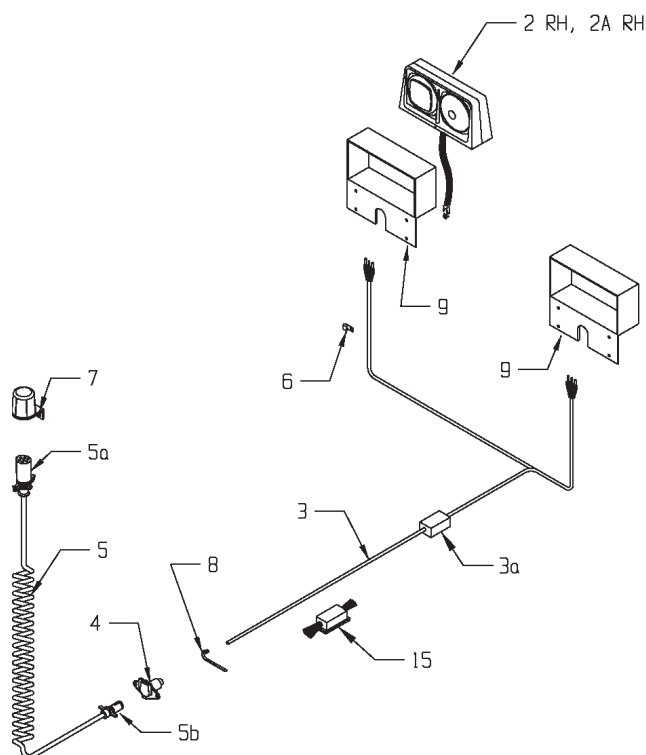

KEY	PART NO.	DESCRIPTION	QTY
1	56-0030	Dual Light LH w/4-Plug	1
1a	56-0030-TR	Truck Mount Dual Light LH w/4-Prong	1
2	56-0031	Dual Light RH w/4-Plug	1
2a	56-0031-TR	Truck Mount Dual Light RH w/4-Prong	1
3	56-0032	Ag Light Harness w/Module	1
3a	56-0032-1	Replacement Module w/pigtails & Instructions	AR
4	56-0004	#1232 4-Way Socket 4-Pin	1
5	56-0005	Coil Cable Assembly	1
5a	56-0012	7-Contact Plug End Only	1
5b	56-0005-1	4-Hole Plug End Only	1
6	56-0008	Harness Frame Clip	1

KEY	PART NO.	DESCRIPTION	QTY
7	56-0009	Stor-A-Way Plug Holder	1
8	65-0006-5	Nylon Tie Straps	1
9	925-3793	Right / Left Light Mount Bracket	1
10	56-0001-3	Bezel Blank, Black	1
11	56-0001-4	#1157 Bulb	1
12	56-0001-2	Red Lens	1
13	56-0001-1	Amber Lens	1
14	46-0001-62	Caution Tail Light Decal	1
15	56-0028	Tail Light Converter (Truck Mount Only)	1

This Page Intentionally Blank.

INSTRUCTIONS FOR AUTOMATIC CHAIN OILER



WARNING: DISCONNECT PTO DRIVE SHAFT AND HYDRAULIC HOSES (RELIEVE HYDRAULIC PRESSURE) BEFORE CLEANING, ADJUSTING, LUBRICATING OR SERVICING THIS SPREADER. FAILURE TO HEED MAY RESULT IN SERIOUS PERSONAL INJURY OR DEATH.

The automatic chain oiler attachment gives a squirt of clean oil to all roller chains every time that the spreaders rear gate, hydraulic cylinder is activated. In this way, the spreaders roller chains get oiled in direct proportion to the number of hydraulic cylinder cycles of the rear gate. This assures adequate lubrication.

New 30 weight oil, which is placed in the reservoir tank mounted on the spreader, is all that is needed to properly lubricate all roller chains and sprockets. The automatic chain oiler does not use any oil from the tractors hydraulic system. The hydraulic hose connected to the bottom of the oiler pump only serves to power the piston in the pump every time that the spreaders rear gate is opened.

Should the oil reservoir tank run dry, pour about a ½ cup of clean 30 weight oil into the tank. Allow time for the oil to run down into the oiler pump slowly and allow air to escape. After thirty minutes to one hour has passed, finish filling the reservoir tank. Make sure that all fittings and brackets are tight when finished filling the tank.



WARNING: HYDRAULIC FLUID ESCAPING UNDER PRESSURE CAN HAVE SUFFICIENT FORCE TO PENETRATE SKIN. KEEP ALL HOSES AND CONNECTIONS IN GOOD SERVICEABLE CONDITION. FAILURE TO HEED MAY RESULT IN SERIOUS PERSONAL INJURY OR DEATH.

While running the tractors hydraulics only, open and close the spreaders rear gate several times. This will cycle the hydraulic cylinder leading to the oiler pump. Keep cycling until oil can be seen in all of the oil lines leading to the oiler brushes. (If you experience problems priming the oiler pump, you may need to bleed air out of the hydraulic hose where it is connected to the pump. Crack the fitting until oil comes out then re-tighten.) The hydraulic cylinder that the oiler pump is tied into is double acting and must reach 300 PSI of pressure to actuate the pump.

When replacing oiler brushes into brush holders, use regular ½"-20 nuts. Tighten nut finger tight initially as some adjustment may be needed later. For best results, place brush holders over top of roller chains and directly on top of sprockets. Adjust brush holders so oiler brushes are pushed down into the roller chain approximately ½". Carefully tighten up the ½"-20 nuts on the oiler brushes. DO NOT over tighten as damage to the brush will occur. The plastic threads of the oiler brush will crack and then break off from the brush body.

IMPORTANT! The 5/32" oil line tubing can only be removed from an oiler brush by pushing in on the red plastic ring and pulling the tubing out while holding the ring down.

The oiler pump is set at the factory to deliver the maximum amount of oil per cycle. If less oil is desired, loosen the jam nut on the bottom of the pump and screw in the adjusting shaft 1/4" or approximately 5 turns. It is not recommended to screw the shaft into the bottom of the oiler pump more than 15 turns as this may not allow for proper lubrication of the roller chains.

IMPORTANT! Always use new 30 weight oil. In cold weather, use a SAE 10 or a mixture of two parts of 30 weight oil to one part diesel fuel.

OIL-KIT

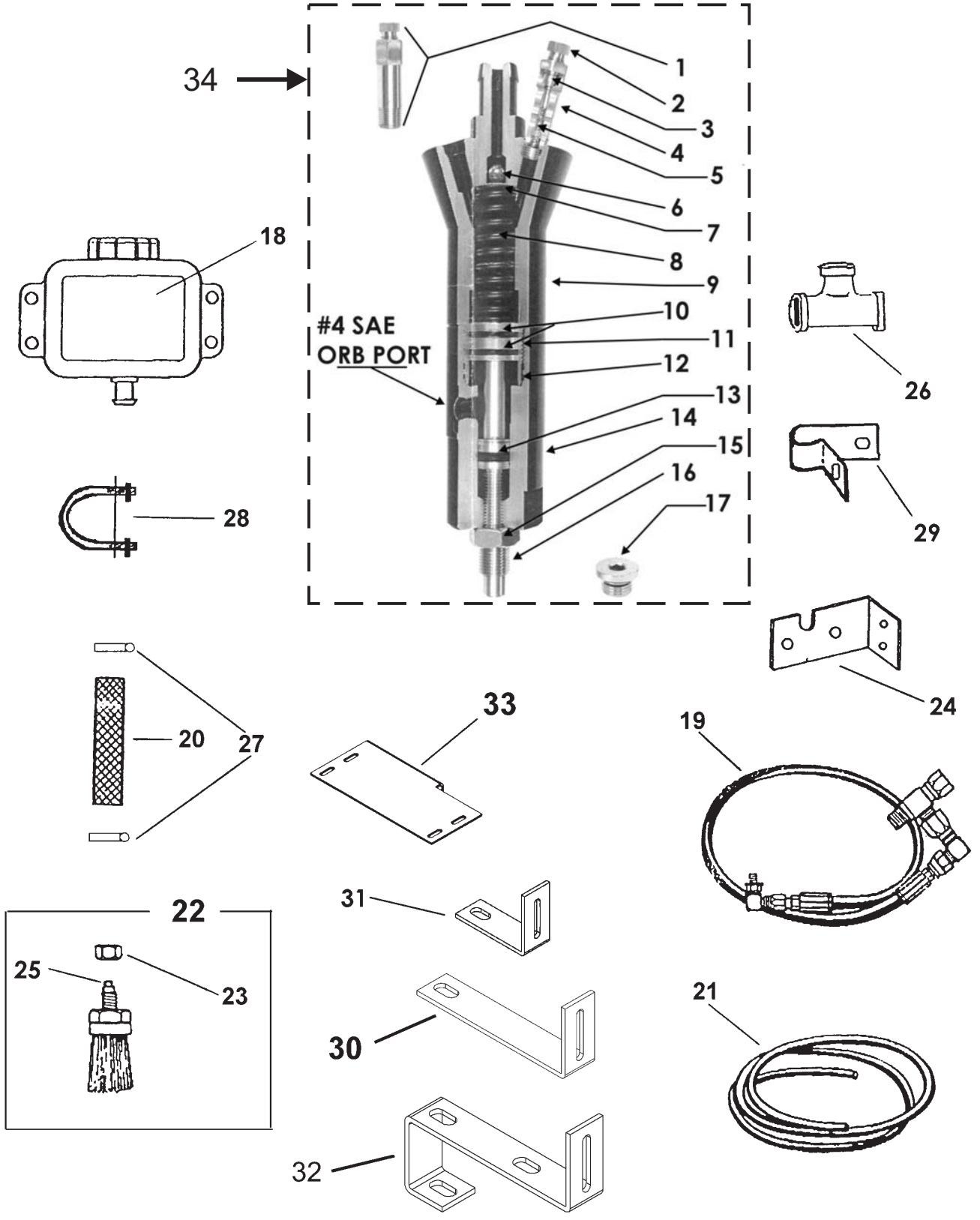

See Page 55 For Oiler Instructions

OIL-KIT

KEY	PART NO.	OEM PART NO.	DESCRIPTION
1	952-0001-1-33	170-4515	Holder, Manifold Valve Assembly
2	952-0001-1-27	576895	Sleeve Nut Brass
3	952-0001-1-28	576894	5/32 Brass Ferrule
4	952-0001-1-13	2510	Holder, Manifold Valve
5	952-0001-1-9	1012	One Way Valve (Schrader Valve)
6	952-0001-1-11	3520	Bearing, 7/16" Stainless
7	952-0001-1-10	1019	Screen Flat Oiler .906 Dia
8	952-0001-1-5	1004	Spring, Oiler
9	952-0001-1-1	1001-6-B	Oiler Body 6 Port Black
10	952-0001-1-8	2-022-N552-90	O Ring, Oiler Piston 2-022 90 Dur
11	952-0001-1-4	1033	Piston, 2 Groove Alum, Short
12	952-0001-1-6	2-026-N552-90	Washer, Rubber Lube Minder
13	952-0001-1-7	2-113-N674-70	O Ring, Adj End Cap Plunger
14	952-0001-1-2	21999-0224	Adj End Cap Oil Black
15	952-0001-1-16	6010	½-20 Jam Nut
16	952-0001-1-3	4511	Plunger, Brass Adj End Cap
17	952-0001-1-32	2107001U	1/8" Hex Head Pipe Plug
18	952-0001-1-18	2550	Reservoir Two Quart Tank
19	952-0001-1-19	M-4555	Hydraulic Hose Assembly Meyer Mfg.
20	952-0001-1-20	7010	Tubing 5/8" ID Clear Polybraid
21	952-0001-1-21	7012	Tubing 5/32" Nylon (Feet)
22	952-0001-1-25	4514	Brush Assembly No 5/32 Insert
23	813-5020-Z		½ 20 Plated Nut
24	952-0001-1-17	2016	Bracket Oiler Mtg Pump
25	952-0001-1-14	2511	5/32 Push In Insert (Nycoil)
26	955-3803		BM Pipe Tee 3/8 x 3/8 x 3/8
27	952-0001-1-30		1" Hose Clamp
28	952-0001-1-31	4517	U-Bolt Assembly # 9
29	08-0050		5-16" Loom Clamp
30	33-8000-7		Brush Holder
31	952-0001-3		Auger Chain Brush Holder
32	952-0001-8		120/140 Chain Brush Holder
33	952-0001-5		Oiler Tank Mount Plate
34	952-0001-1-36	170-000-6	Oiler Body Pump Assy, Complete

MEYER INDUSTRIAL SPREADER

“TROUBLE SHOOTING”

	SYMPTOM	PROBLEM	SOLUTION
AUGERS	Augers shake or chatter	Stiff roller chains - dry Loose roller chains Worn sprockets/chain Dry auger trough	Lubricate roller chains Tighten roller chains Replace sprockets/chains Load auger trough w/manure
	Augers wobble/lift up & down	Worn auger shaft bushings Worn auger hold down nylon bearings	Replace auger shaft bushings Replace auger hold down nylon bearings
FLOW CONTROL GATE	Will not lift	No hydraulic supply Froze tight w/build-up	Supply hydraulic power Thaw frozen build-up
	Will not close/seal	Lodged foreign object/dirty	Remove foreign object/clean
	Sticks/binds	Dirty/dry slide guides Worn slide guides Worn out slide guide polyslick	Clean/lubricate slide guides Replace slide guides Replace slide guide polyslick
GEAR BOXES	Clunking sounds	Gears/bearings wearing Low oil or fluid gear grease	Replace gears/bearings Fill with #80-#90 wt. Gear lube oil or fluid gear grease
	Excessive oil use	Worn out oil seals Dry manure & twine wrapping	Replace oil seals Clean & remove build-up at seal areas
	Gear damage	High speed/full load start-up Worn out gears	Slow start-up, fill with oil Replace gears
MATERIAL GUIDES	Dirty/build-up	Too slow spinner RPM's	Operate spreader at recommended RPM's
PTO SHAFT	Whips/shakes	Over extended or bent PTO	Adjust tractor drawbar length - See Page 8
	Vibrates up & down	Spreader center shaft bent	Replace center shaft
	Worn Universal Joints	Lack of lubrication/used	Lubricate joints daily replace joint
ROLLER CHAINS AND SPROCKETS	Excessive chain wear	Lack of lubrication Out of alignment/loose	Lubricate/align/tighten
	Roller chain breakage	Loose roller chain Worn sprockets	Tighten roller chains Replace sprockets
	Sprocket teeth tipped over	Worn roller chain Bad roller bearings	Replace roller chain Replace bearings
SPINNERS PADDLES/ TEETH	Spinners turn hard/squeak	Bad lower spinner bearings	Replace lower spinner bearings
	Shake at high RPM's (excessive vibration)	Spinner bent/out of balance	Straighten/balance/replace spinner
	Excessive paddle damage	Wobbled out lower spinner shaft	Replace or reweld lower spinner shaft
		Too slow spinner RPM's Lodging of manure	Operate spreader at recommended RPM's Adjust material guides Straighten/replace paddles
	Spreading foreign objects	Avoid loading foreign objects	

MEYER EQUIPMENT WHEEL TORQUE

BOLT/STUD SIZE	SOCKET SIZE	PRESS FORMED WHEEL CENTER	BOLT TYPE	HEAVY DUTY WHEEL CENTER
1/2	3/4	80 ft lbs	Lug Bolt	85 ft lbs
9/16	7/8	80 ft lbs	Lug Bolt	120 ft lbs
5/8	15/16 / 1-1/16	100 ft lbs	Bevel or Flange Nut	160 ft lbs
3/4	1-1/8 / 1 1/2		Flange Nut	378 ft lbs

8720/8865 SPREADER W/ BRAKES TIRE WHEEL TORQUE

- Clean adjoining surfaces
- Start nuts to bring wheel and brake drum flush to hub mounting surface.
- Avoid brake drum and/or wheel binding on hub.
- Install remaining wheel nuts. Torque to 50 ft-lbs. Then re-torque to 450-500 ft-lbs (22mm) or 265 ft-lbs (3/4").
- Re-torque wheel nuts after 50-100 miles.
- Check wheel nut torque every 10,000 miles and re-torque as necessary.



CAUTION: THESE INSTRUCTIONS ARE NOT COMPLETE. READ AND FOLLOW ALL PROCEDURES IN USER'S GUIDE TO WHEELS AND RIMS BY "THE MAINTENANCE COUNCIL" #T0410. IF YOU HAVE QUESTIONS CALL WALTHER ENG. & MFG. COMPANY INC. (937)847-2700.

TIRE INFLATION

TIRE SIZE	PLY	PSI
11L-15	8	36
12.5L-15	8	36
12.5L-15	12	52
14L-16	12	44
16.5L-16	10	36
19LX16.1	10	32
21.5L-16.1	18	44
11R/22.5	used truck	75
425/65X22.5	used truck	75
28L-26	16	28

MEYER INDUSTRIAL SPREADER DIMENSIONS & SPECIFICATIONS

	Industrial 8720 Trailer Type w/ 21.5 Tires “	Industrial 8720 Truck Mount w/ Mount Brkts.	Industrial 8856 Trailer Type w/ 28L x 26 Tires	Industrial 8865 Truck Mount w/ Mount Brkts.
CAPACITY				
Bushels Heaped	720	720	865	865
Gallons/Cu.ft. (Struck)	3500/468	3500/468	4200/562	4200/562
Cu. Yards. (struck)	17.33 cu. yards	17.33 cu. yards	20.8 cu. yards	20.8 cu. yards
DIMENSIONS				
Overall Length	26'6”	20'10” w/ Hyd Motor	29'10”	24'2” w/ Hyd Motor
Inside Tank Length	16'8”	16'8”	20'	20'
Loading Height	87” w/21.5 or 425/65 91” w/16.00X20	68” Plus Truck Height	88” w/28L x 26	68” Plus Truck Height
Overall Height - Top of Splash Guard	96” w/21.5 or 425/65 100” w/16.00X20	77” Plus Truck Height	97” w/28L x 26 Tires	77” Plus Truck Height
Overall Width (std. Axle) Outside Tires	118” w/21.5L 114” w/16.00X20	101”	N/A	101”
Overall Width w/high Floatation axle pkg.	141” w/28L x 26		141” w/ 28L x 26 Tires	
Top Inside Tank Width	101”	101”	101”	101”
SPECIFICATIONS				
Total Weight	13,720#	9,400#	18,020#	10,700#
Maximum Load Net (Lbs.)	35,200#	35,200#	38,000#	38,000#
Lower Auger Diameter	23”	23”	23”	23”
Lower Auger Flighting Thick- ness	3/8” Sectional	3/8” Sectional	3/8” Sectional	3/8” Sectional
Independent Lower Auger Shear Hub Sprockets	Standard	Standard	Standard	Standard
3rd Auger (solid material)	Standard - 16”	Standard -16”	Standard - 16”	Standard - 16”
Drive - PTO-RPM	1000 RPM Con- stant Velocity 1 3/8-21 spline	PTO - Direct Std. Hydrostatic-Opt.	1000 RPM Con- stant Velocity 1 3/4-20 Spline	PTO - Direct Std. Hydrostatic-Opt.
Drive Line Protection	Overrunning Cut Out Clutch w/ Shear Bolt Au- gers	Cut Out Clutch w/ Shear Bolt (Pto Version)	Overrunning Cut Out Clutch w/ Shear Bolt Au- gers	Cut Out Clutch w/ Shear Bolt (Pto Version)
Roller Chain Drive	80-120-140	80-120-140	80-120-140	80-120-140
Roller Chain Auto Oiler	Standard	Standard	Standard	Standard
Expeller Speed (RPM)	716 RPM	716 RPM	716 RPM	716 RPM
Expeller Diameter	30”	30”	30”	30”
TANK CONSTRUCTION				
Material	Copper Bearing Steel	Copper Bearing Steel	Copper Bearing Steel	Copper Bearing Steel
Thickness - Auger Troughs	1/4”	1/4”	1/4”	1/4”
Thickness - Tank Sides	3/16”	3/16”	3/16”	3/16”

SPECIFICATIONS SUBJECT TO CHANGE WITHOUT NOTICE.

MEYER INDUSTRIAL SPREADER DIMENSIONS & SPECIFICATIONS

Frame Construction	Heavy 8" Channel	Heavy 8" Channel	Heavy 8" Channel	Heavy 8" Channel
Door Opening	32" x 53"	32" x 53"	32" x 53"	32" x 53"
Standard Axle Spindle Diameter	Standard Tandem 3 1/2" Sleeved		N/A	
High Floatation Axle Spindle Diameter	Optional Tandem 4 1/2" Sleeved		Standard Tandem 4 1/2" Sleeved	
Standard Axle Hub Size	10 Bolt-15,000#		N/A	
High Floatation Axle Hub Size	10 Bolt-20,000# (opt.)		10 bolt-20,000# (std.)	
Splash Shields-Standard	45 Front/45 Rear	45 Front/45 Rear	45 Front/45 Rear	45 Front/45 Rear
Lights w/hookup cord	Standard	Standard	Standard	Standard
Tractor Requirement PTO HP (Min.)	130 HP Tractor		160 HP Tractor	
OPTIONS				
1000 RPM 1 3/8"-21 Spline	Standard		Optional	
1000 RPM 1 3/4"-20 Spline	Optional		Standard	
Hydraulic Lid	Optional	Optional	Optional	Optional
Poultry Litter Package	Optional	Optional	Optional	Optional
High Floatation Axle Package	Optional		Standard	
Hyd. Brakes-HF axle only	Optional (2 or 4 wheel)		Optional (2 or 4 wheel)	
Safety Chain	Optional		Optional	
Truck Mount Drive Options		PTO - Direct Std. Hydrostatic - Opt		PTO - Direct Std. Hydrostatic - Opt
Hyd. Drive Expellers W/variable auger speeds	N/A	Optional	N/A	Optional

SPECIFICATIONS SUBJECT TO CHANGE WITHOUT NOTICE.

MEMBER



**Manufactured by:
Meyer Mfg. Corp.**

County Hwy. A West
P.O. Box 405
Dorchester, Wisconsin 54425-0405
Phone 715-654-5132 • FAX 715-654-5513
1-800-325-9103



www.meyermfg.com

E-mail: sales @meyermfg.com

Farm Equipment Buyers Trust the Name Meyer!

